

**Request for Proposal No. 018.19.B5
For
Telecommunications Consulting Services**

Date	Event
Bid Advertised	Thursday, October 4, 2018
Pre-Bid Conference	Wednesday, October 10, 2018, 1:00 pm EST
Last Date for Questions	Tuesday, October 16, 2018
Bid Due	Friday, October 19, 2018, 2:00 pm EST
Bid Evaluation Complete	Wednesday, October 24, 2018
Board Approval	Thursday, November 15, 2018
Contract Execution	Friday, November 16, 2018

Introduction and Background

The Howard County Public School System (HCPSS) has issued this Request for Proposals (RFP) to solicit submittals from qualified professional services firms to provide the Department of Information Technology (IT) with an assessment of its current voice telecommunication environment and various options available in the design and implementation of a forward-looking Unified Communications solution. A critical component of this work will be a detailed review of the Total Cost of Ownership (TCO) of available options.

Howard County, Maryland is a suburban community of over 317,233 situated midway along the Baltimore-Washington corridor. It is a county of contrasts - a blend of old and new, urban and rural, historical and progressive. The county's borders encompass Ellicott City, one of the country's oldest towns, and Columbia, a planned community conceived and designed 50 years ago by The Rouse Company. A great community deserves great schools, and HCPSS is a recognized source of local pride. HCPSS is a school system of 76 schools, elementary, middle, high, and special schools. The school system consistently ranks among Maryland's top school districts based on student performance on the Maryland School Assessments. Howard County students score above the national averages on standardized tests and over 85% of graduates continue their education beyond high school. Respondents to this solicitation are encouraged to review additional information about the school system at <http://www.hcpss.org/about-us/>.

HCPSS School System Tax Identification.

Federal Tax Id:	52-6000968
Maryland Sales Tax:	30001219
Federal Excise Tax:	52-73-0257k

Human Resources - HCPSS employs approximately 8,000 full- and part-time regular employees in addition to a large number of temporary and seasonal employees. Approximately 400-500 employees (full-time and regular part-time) are hired each year with an average of 3,000 applications received. The Office of Human Resources is responsible for the recruitment and hiring of all staff in collaboration with other HCPSS offices.

Respondents to this solicitation are encouraged to review the data contained in HCPSS's website for a better understanding of HCPSS, its organization and management, and the services it provides. The website is <http://www.hcpss.org>.

SECTION I. SOLICITATION INSTRUCTIONS

1. Issuing Office. The Issuing Office shall be the sole point of contact within HCPSS for purposes of the preparation and submittal of proposals in response to this solicitation.

Ted Ludicke
Purchasing Office
Howard County Public School System
10910 Clarksville Pike
Ellicott City, MD 21042
Phone: (410) 313-5644
Fax: (410) 313-6789
Email: Ted_Ludicke@hcpss.org
<http://www.hcpss.org/about-us/purchasing/>

2. Questions and Inquiries. All questions and inquiries regarding this procurement shall be directed to the individual(s) referenced within the Issuing Office above. Questions shall be submitted in writing via email to Ted_Ludicke@hcpss.org. Inquiries will receive a written reply. Copies of replies will be sent to all other Offerors, but without identification of the inquirer. All such questions and inquiries shall be received by the date and time as listed on the Cover and the Solicitation Schedule of this RFP.
3. Pre-Proposal Conference. A Pre-Proposal Conference will be held in conjunction with this RFP on Wednesday, October 10, 2018 at 1:00 pm at the main HCPSS building located at 10910 Route 108, Ellicott City, MD.
4. Bid Submittal Process.
 - 4.1. Bids are to be provided to the Issuing Office in accordance with the Solicitation Schedule.
 - 4.2. Bids are to be submitted electronically in PDF, format or as indicated, on a USB Flash Drive with the RFP name and number identified clearly on the sealed packet or envelope. Bid responses must be submitted to the Howard County Department of Education, Purchasing Office, 10910 Route 108, Ellicott City, Maryland 21042, no later than the time and date specified on the bid cover sheet.
 - 4.3. LATE BIDS CANNOT BE ACCEPTED.
5. Acceptance of Terms and Conditions. By submitting a Proposal, an Offeror shall be deemed to have accepted the terms, conditions, and requirements set forth in this RFP. The RFP, including all addenda, shall be incorporated into the Contract by reference.
6. Contractual Agreement and Term. Any Contract arising from this RFP action shall commence on the date the Contract is executed on behalf of HCPSS, or such other date as HCPSS and the Contractor shall agree.
7. Withdrawal of Bids. Offers may be withdrawn by written, facsimile, or electronic notice if given prior to the RFP opening time and date. Verbal requests via phone are not acceptable. No offer shall be withdrawn after the scheduled closing time for opening bids.
8. Rejection or Acceptance of Proposals. HCPSS reserves the right to: (i) accept or reject any and all proposals, in whole or in part; (ii) to waive minor irregularities; and (iii) to negotiate in any manner necessary to best serve the interests of HCPSS. Further, HCPSS reserves the right to make a whole award, multiple awards, a partial award, or no award at all. Offerors judged by the Purchasing Office not to be responsible or Offerors whose Proposals are classified as not reasonably susceptible to being selected for award shall be so notified. HCPSS reserves the right to increase or decrease the quantities of any materials, equipment, supplies or services.
9. Right to Amend, Modify or Withdraw. HCPSS reserves the right, in their sole discretion, to amend, or modify any provisions of this solicitation, or to withdraw this solicitation at any time prior to the award of a Contract. The decision of HCPSS shall be administratively final in this regard.
10. Modifications of Technical Proposal. Offerors may not modify, supplement, cure, or change proposals in any way after the due date and time unless specifically requested by HCPSS.

11. RFP Response Materials. All written materials submitted in response to this RFP become the property of HCPSS and may be appended to any formal documentation that would further define or expand the contractual relationship between HCPSS and the Contractor(s).
12. Duration of Offers. Proposals shall remain irrevocable for 120 days following the closing date of the Proposal due date. This period may be extended by mutual agreement between the Offeror and HCPSS.
13. Incurred Expenses. HCPSS is not responsible for any expenses that Offerors may incur in preparing and submitting Proposals or in making oral presentations of their Proposals, if required.
14. Confidentiality. Offerors should give specific attention to the identification of those portions of the Proposal that the Offeror deems to be confidential, proprietary information, or trade secrets and provide any justification why such materials, upon request, should not be disclosed by HCPSS under the Freedom of Information Act (FOIA). Offerors are advised that, upon request for this information from a third party, the Purchasing Office is required to make an independent determination as to whether the information may or may not be disclosed to the requesting party. That decision will take into consideration the Offeror's position regarding its Proposal. A blanket statement by an Offeror that its entire Proposal is confidential or proprietary will not be considered.
15. Multiple Proposals. Offerors may not submit more than one Proposal.
16. Alternate Proposals. Offerors may not submit an alternate for this RFP.
17. Forms. This solicitation is designed for the Offeror to fill in responses where indicated. This entire solicitation document, along with any attachments indicated with the responses filled in, is to be submitted as the main part of the Offeror's proposal. The Offeror may adjust forms and insert space as needed for responses; however, the Offeror shall not alter any language provided by HCPSS in this solicitation; any such alterations will not be honored, and the Offeror will be bound by the language in the solicitation as published. Any changes to the solicitation language shall be explicitly requested.
18. Addenda Acknowledgment. Offerors shall acknowledge in writing the receipt of any and all addenda, amendments, and/or changes issued. Such acknowledgement shall be included in the Technical Proposal. It is the Offeror's sole responsibility to monitor the Purchasing web site prior to submitting their RFP for any addenda, amendments, and/or changes issued.
19. Signature. The enclosed form titled "SIGNATURE SHEET" shall be completed and submitted with Offeror's proposal. The Signature Sheet shall be signed by the person or persons legally authorized to sign contracts on behalf of the offering company.
20. Resolution of Disputes. Bid rejection for non-responsiveness and/or non-responsibility shall be made based on criteria established in the solicitation documents.
 - 20.1. Protests shall be filed in writing to the Purchasing Office prior to the Board of Education award of the contract award. Protests shall include the basis for the protest or appeal, complete in all respects, with relief sought, and whether the protester wishes to have a hearing with respect to the protest or appeal.
 - 20.2. Protests shall be addressed to Howard County Department of Education, 10910 Route 108, Ellicott City, MD 21042, Attn: Doug Pindell, Purchasing Officer, labeled "Protest". The written protest shall include as a minimum the following:
 - 20.2.1. Name and address of the protester
 - 20.2.2. Appropriate identification of the bid
 - 20.2.3. Supporting exhibits, evidence, and/or documents to substantiate any claims.
 - 20.2.4. Suggested remedy(ies)

SECTION 2. TERMS AND CONDITIONS

1. Contractor's/Offorer's Responsibility. Offerors are advised to read the requirements very carefully to ensure that each requirement is understood. If in doubt, develop and submit applicable questions in writing to the contact at the Issuing Office. An Offeror's misinterpretation of requirements shall not relieve the Offeror of the responsibility to address accurately the requirements of the RFP or to perform the Contract, if awarded. HCPSS will enter into a contractual agreement with the selected Contractor(s) only. The selected Contractor(s) shall be solely responsible for all services as required by this RFP. Subcontractors, if any, will be the responsibility of the Contractor(s) and the role of subcontractors shall be clearly identified in the proposal. The use of a subcontractor(s) does not relieve the Contractor(s) of liability under a Contract.
2. Contractor Responsibilities and Use of Subcontractors. HCPSS shall enter into contractual agreement with the selected Contractor(s) only. The Contractor(s) shall be responsible for all products and/or services required by this RFP. HCPSS will not consider Proposals that reflect primary and secondary service providers or a prime/subcontractor relationship.
3. Non-Discrimination in Employment. The Contractor agrees: (a) not to discriminate in any manner against an employee or applicant for employment because of race, color, religion, creed, age, sex, marital status, national origin, ancestry, or physical or mental disability unrelated in nature and extent so as reasonably to preclude the performance of such employment; (b) to include a provision similar to that contained in subsection (a), above, in any subcontract except a subcontract for standard commercial supplies or raw materials; and (c) to post and to cause subcontractors to post in conspicuous places available to employees and applicants for employment, notices setting forth the substance of this clause.
4. Behavior of Contractor Employees/Subcontractors. HCPSS is committed to providing a work and study environment that is free from discrimination and harassment on the basis of race, color, religious creed, ancestry, national origin, age, sex, marital status, handicap, pregnancy, or status as a disabled veteran or veteran of the Vietnam era. Behavior contrary to this philosophy, which has the purpose or effect of creating an intimidating, hostile, or offensive environment, will not be tolerated by HCPSS, and it is the Contractor's responsibility to ensure that such behavior by its employees, agents, and subcontractors does not occur. The policy extends to maintaining an environment free from sexual harassment. Therefore, sexual advances or sexual remarks, requests for sexual favors, and other verbal or physical conduct of a sexual nature shall not be condoned or permitted by the Contractor. This prohibition extends to such harassment within the employment context as well as harassment of students, staff, and visitors to the HCPSS. It should be assumed that all sexual behavior by the Contractor's employees, agents, and subcontractors on any campus or facility of HCPSS, whether owned, operated, maintained or leased by the HCPSS, is improper and unwelcome. Contractor will also insure that all technicians who work with HCPSS users exhibit a high degree of professionalism in their dealings with those users. The Contractor's employees and subcontractors shall be subject to and comply with all applicable HCPSS rules, regulations and policies which shall include those regulations relating to safety, security and campus parking. If deemed necessary, HCPSS reserves the right to demand the removal of any of the Contractor's employees/subcontractors from duty on its premises as a result of their violation of the standards set forth herein.
5. Tobacco Free and Alcohol/Drug Free Environment. HCPSS maintains a tobacco, alcohol/drugfree environment. The sale or use of tobacco, alcohol or drugs, in any form, or related product, is prohibited in school buildings and grounds at all times. Persons found violating this policy will be requested to remove the product and themselves from school premises.
6. Criminal History Background Checks. All employees, agents, or representatives of the awarded contractor who will be performing work on any phase of the contract arising out of this Bid may be subject to a criminal history background check by the school system. Such persons, if requested by the school system, shall provide fingerprints and other required information to facilitate such a check, as well as the necessary fees to obtain such a check from the federal or state government. At the completion of a background check, the school system may, at its sole discretion, decide that a particular employee, agent, or representative of the contractor be barred from school system property.
7. Child Sex Offender Notification.

- 7.1. Sex Offender Requirement: Maryland law requires certain sex offenders to register with the local law enforcement agency; See Maryland Annotated Code, Criminal Procedure Article, §11- 704. One of the purposes of this law, is to inform school systems when a Registered Sex Offender is residing or working in the area. When the sex offender registers, the local police are required to notify the Superintendent of Schools, and the Superintendent, in turn, is required to send a notice to school principals.
- 7.2. As a contractor working for HCPSS we require that you do not employ Registered Sex Offenders to work on projects for our school system if they, as a result, are required to perform delivery, installation, repair, construction or any other kind of services on HCPSS property. Further, Maryland Law that became effective June 22, 2006, requires that any person who enters a contract with a county board of education or a non-public school "may not knowingly employ an individual to work at a school" if the individual is a registered sex offender; See §11- 722 Criminal Procedure Article. An employer who violates this requirement is guilty of a misdemeanor and if convicted may be subject to up to five years imprisonment and/or a \$5,000 fine.
- 7.3. Each contractor shall screen their workforce to ensure that a Registered Sex Offender does not perform work at a county public school and also ensure that a subcontractor and independent contractor conducts screening of its personnel who may work at a school. The term "workforce" is intended to refer to all of the contractor's direct employees and subcontractors and/or independent contractors it uses to perform the work. Violations of this provision may cause HCPSS to take action against the contractor up to and including termination of the contract.
- 7.4. Effective July 1, 2015, amendments to § 6-113 of the Education Article of the Maryland Code further require that a contractor or subcontractor for a local school system may not knowingly assign an employee to work on school property with direct, unsupervised, and uncontrolled access to children, if the employee has been convicted of, or pled guilty or nolo contendere to, a crime involving a sexual offense, child sexual abuse and crimes of violence.
- 7.5. The Contractor shall submit to HCPSS a listing of any employees assigned to perform under this agreement and certify that the necessary criminal history records checks have been conducted and that each employee complies with the requirements.
8. Occupied Buildings. Work under this contract and any resulting contract or sub- contract will take place while school facilities are occupied by staff and often also by students and visitors. Every precaution shall be exercised to protect people from injury and to minimize disruption of activity. As well, contract employees shall conduct themselves in a professional manner while on HCPSS's premises. Any employee found to disregard the nature of the school system's surroundings shall be removed from the premises and may be prohibited from further servicing the HCPSS contract.
9. Identification and Sign-in Procedures. All contractor personnel, working in or around buildings designated under this contract, shall have a valid driver's license or photo ID in their possession at all times. Contractors are required to provide identification and sign-in and sign-out at the front office at each site on a daily basis during the course of each project or they may receive a HCPSS badge allowing them to access the job site without signing in and out.
10. Ethics Regulations.
 - 10.1. The Board of Education of Howard County has adopted an Ethics Regulation policy. Required by the Annotated Code of Maryland, these Ethics Regulations cover members of the Board of Education, the Superintendent, and all employees; and it specifies limits of participation of these individuals with entities doing business with HCPSS. For a copy of the regulations, please contact the Purchasing Office, Howard County Department of Education (410) 313- 6644.
 - 10.2. Any resulting Contract is cancelable in the event of a violation of the HCPSS Ethics Regulation policy or the Maryland Public Ethics Law by a Contractor or any HCPSS employee in connection with this procurement.
11. Taxes. HCPSS is exempt from Federal Excise Taxes, Maryland Sales and Use Taxes. Exemption Certificates shall be provided upon request. In the instance a Contractor is required to furnish and install material in the construction or improvement of real property in performance of a Contract, the Contractor shall pay the Maryland Sales Tax and the exemption will not apply.

12. Multi-Agency Participation.

- 12.1. Under §5-112, Paragraph (3) of the Education Article of the Annotated Code of Maryland HCPSS may with Board of Education approval participate in contracts for goods or commodities that are awarded by other public agencies or by intergovernmental purchasing organizations if the lead agency for the contract follows the public bidding procedures. HCPSS therefore reserves the right to extend the terms and conditions of this solicitation to any and all other agencies within the state of Maryland as well as any other federal, state, municipal, county, or local governmental agency under the jurisdiction of the United States and its territories. This shall include but not limited to private schools, parochial schools, non-public schools such as charter schools, special districts, intermediate units, non-profit agencies providing services on behalf of government, and/or state, community and/or private colleges/universities that require these goods, commodities and/or services. A copy of the contract pricing and the requirements incorporated in this contract will be supplied to requesting agencies.
- 12.2. Each participating jurisdiction or agency shall enter into its own contract with the awarded Offeror(s) and this contract shall be binding only upon the principals signing such an agreement. Invoices shall be submitted in duplicate "directly" to the ordering jurisdiction for each unit purchased. Disputes over the execution of any contract shall be the responsibility of the participating jurisdiction or agency that entered into that contract. Disputes shall be resolved solely between the participating agency and the awarded Offeror(s).

SECTION 3. SPECIAL TERMS AND CONDITIONS

1. Agreement. Contractor shall provide to HCPSS professional services in accordance with the terms and conditions of this solicitation.
 - 1.1. The resulting Contract consists of multiple documents as follows in order of precedence:
 - 1.1.1. The Contract Form
 - 1.1.2. The Request for Proposal and all amendments to the solicitation
 - 1.1.3. Contractor's Technical Proposal and Price Proposal as accepted by HCPSS
 - 1.2. All terms and conditions of HCPSS's solicitation, and any amendments thereto, are part of this Agreement unless expressly contradicted by a term or condition of this Agreement. Proposals or suggestions of the Contractor for changes in the solicitation or the terms and conditions of the contract are not binding upon HCPSS and are not a part of this Agreement unless set forth in an amendment of the solicitation or in this Agreement and agreed to in writing by HCPSS.
2. Contract Period. The initial Contract term shall be for one (1) year from the date of contract execution. HCPSS may solely authorize one (1) additional one-year term (a maximum total of two one-year terms) pending successful performance and availability of funds.
3. Eligibility to Participate in Resultant RFP. The Contractor awarded a contract through this RFP will be ineligible to submit bids or proposals for HCPSS's Telecommunications Solution RFP resultant from said Contractor's services.
4. HCPSS Program Coordinator. HCPSS will designate a staff member to act as coordinator ("Program Coordinator") between HCPSS and the Contractor. Throughout the period of the Contract, copies of all correspondence, work products, specifications, estimates and other materials prepared by the Contractor should be directed to the Program Coordinator and also to any other HCPSS personnel designated by the Program Coordinator. Direct contact or communication by the Contractor with other HCPSS offices or any other entity concerning the Contract shall be made only with the prior knowledge and concurrence of the Program Coordinator.
5. Professional Services. The Contractor shall utilize personnel named and/or otherwise identified in its submittal responding to HCPSS's solicitation unless (a) a change is requested by the Contractor and approved in writing by the Program Coordinator; or (b) a change is requested in writing by the Program Coordinator for good cause, in which case the Contractor shall make an appropriate substitution, subject to HCPSS's approval, and notify HCPSS in writing. Major changes in the Contractor's organization or personnel (other than the Contractor's Team) shall be reported to HCPSS in writing as they occur.
6. Billing and Payment.
 - 6.1. The contractor shall submit invoices to the attention of the selected Program Coordinator, Howard County Department of Education, 10910 Rt. 108, Ellicott City, MD 21042.
 - 6.1.1. Invoices shall contain the following information:
 - 6.1.1.1. Purchase Order Number
 - 6.1.1.2. Description of work along with number of hours expended
 - 6.1.1.3. Total due
 - 6.2. All fees are exclusive of applicable federal, state, local, and foreign sales, use, excise, utility, gross receipts, value added and other taxes, tax-like charges and tax-related surcharges. HCPSS is generally exempt from such taxes, and Contractor agrees not to charge HCPSS for such taxes in accordance with applicable law. HCPSS will provide exemption certificates upon request.
 - 6.3. The HCPSS provides payments on a net 30-day basis for HCPSS approved invoices.
7. Acceptance Procedure. HCPSS will make every effort to pay the Contractor within thirty (30) days of acceptance of all deliverables associated with each invoice. Notwithstanding any other provision of this RFP, all invoices must be accompanied with documentation that details the number of hours expended and nature of work performed by Contractor's personnel and/or subcontractor staff in the performance of work under the Contract.

8. Confidential Information.

- 8.1. Contractor acknowledges and understands that HCPSS is required to protect certain Confidential Information from disclosure under applicable law, including but not limited to, the Family Educational Rights and Privacy Act ("FERPA"), the Gramm Leach Bliley Act ("GLBA"), or the Maryland Public Information Act ("PIA"), including regulations promulgated there under, as the laws and regulations may be amended from time to time (collectively the "Privacy Laws").
- 8.2. The Confidential Information that is protected under FERPA was provided to the Contractor as it is handling an institution service or function that would ordinarily be performed by HCPSS's employees. The Contractor agrees that it shall be obligated to protect the Confidential Information in its possession or control in accordance with the Privacy Laws to the same extent as HCPSS would be obligated if the Confidential Information was in the possession or control of HCPSS. The Contractor further agrees that it is subject to the requirements governing the use and re-disclosure of personally identifiable information from education records as provided in FERPA.
- 8.3. Contractor's obligations with respect to Confidential Information shall survive the expiration or the termination of this Contract.
- 8.4. Contractor acknowledges that Contractor's failure to comply fully with the restrictions placed upon use, disclosure and access to Confidential Information may cause HCPSS grievous irreparable harm and injury. Therefore, any failure to comply with the requirements of this Section shall be a material breach of this Contract.
- 8.5. Contractor agrees and acknowledges that it is not the custodian of any Confidential Information that may be in Contractor's possession or control. Contractor shall forward any request for disclosure of Confidential Information to:

Public Information Office
The Howard County Public School System
10910 Clarksville Pike
Ellicott City, MD 21042

9. Relationship of The Parties. It is understood and agreed that Contractor is an independent contractor of HCPSS, and not an employee. Except as set forth in this Contract, the HCPSS will not withhold income taxes, social security or any other sums from the payments made Contractor hereunder. All employees or contractors of Contractor shall in no way be considered employees of HCPSS, but rather they shall be employees or contractors of Contractor, and Contractor shall bear full responsibility for compensating those persons and for the performance of the Services by way of them.
10. Insurance. Contractor shall maintain in full force and effect adequate insurance coverage to protect against the risks associated with the performance of Services under this Contract, as further set forth in HCPSS Insurance Requirements, or as set forth in Contractor's proposal should the coverage and limits therein exceed the required minimum levels. Contractor shall provide to the Purchasing Office a certificate of insurance including evidence of the required limits at the execution hereof, and annually thereafter.
11. Indemnification. The Awarded Contractor shall be responsible for any loss, personal injury, expense, death and/or any other damage which may occur by reason of Contractors acts, negligence, willfulness or failure to perform any of its obligations under this agreement. Furthermore, any acts on the part of any agent, director, partner, servant or employee of the Contractor are deemed to be the Contractors acts. Contractor agrees to indemnify and hold harmless HCPSS and its Board of Trustees, Employees, Agents and Students from any claim, damage, liability, expense, and/or loss, including defense costs and attorney fees, arising directly or indirectly out of the Contractor's performance under this agreement. The indemnification obligation of the successful Contractor shall include but shall not be limited to injuries to individuals and property of individuals who are not parties to the contract. In addition, the indemnification obligation of the successful Contractor shall cover the acts or omissions of any subcontractors hired by the successful Contractor. Furthermore, the indemnification obligation of the successful Contractor shall survive termination of the contract for any reason. Neither party shall be liable to the other for indirect, consequential, incidental, punitive, exemplary, or special damages, or losses, including without limitation lost profits and opportunity costs.

12. Termination for Default. If the Contractor fails to fulfill its obligation under this Contract properly and on time, or otherwise violates any provision of the Contract, HCPSS may terminate the Contract by written notice to the Contractor. The notice shall specify the acts or omissions relied upon as cause for termination. HCPSS will provide Contractor a reasonable opportunity, not to exceed 10 business days, to cure the act or omission, provided such opportunity to cure does not extend the deadline for any deliverables and does not cause HCPSS further damage. All finished or unfinished work provided by the Contractor, to which HCPSS is entitled pursuant to this Contract shall become HCPSS's property. HCPSS shall pay the Contractor fair and equitable compensation for satisfactory performance prior to receipt of notice of termination, less the amount of damages caused by Contractor's breach. If the damages are more than the compensation payable to the Contractor, the Contractor will remain liable after termination and HCPSS can affirmatively collect damages.
13. Termination for Convenience. The performance of work under this Contract may be terminated by HCPSS in accordance with this clause in whole, or from time to time in part, whenever HCPSS shall determine that such termination is in the best interest of HCPSS. HCPSS will pay all reasonable costs associated with this Contract that the Contractor has incurred up to the date of termination and all reasonable costs associated with termination of the Contract. However, the Contractor shall not be reimbursed for any anticipatory profits that have not been earned up to the date of termination.
14. Delays and Extension of Time. The Contractor agrees to prosecute the work continuously and diligently and no charges or claims for damages shall be made by it for any delays or hindrances from any cause whatsoever during the progress of any portion of the work specified in this Contract. Time extensions will be granted only for excusable delays that arise from unforeseeable causes beyond the control and without the fault or negligence of the Contractor, including but not restricted to, acts of God, acts of public enemy, acts of the State in either its sovereign or contractual capacity, acts of another Contractor in the performance of a contract with the State or HCPSS, changes in law or regulation, action by government or other competent authority, fires, earthquakes, floods, epidemics, quarantine restrictions, strikes, freight embargoes, malicious or criminal acts of third parties, or delays of subcontractors or suppliers arising from unforeseeable causes beyond the control and without the fault or negligence of either the Contractor or the subcontractors or suppliers.
15. Liquidated Damages: Contractor acknowledges and agrees that time is of the essence as to the production and delivery of all products and/or services identified in the document. It is important that deliverables arrive on time. If delivery of products and/or services arrives after specified completion dates, the Contractor shall be liable for liquidated damages not to exceed the Contractor's quoted fees and pricing.
16. Suspension of Work. The Purchasing Office unilaterally may order the Contractor in writing to suspend, delay, or interrupt all or any part of its performance for such period of time as the Purchasing Office may determine to be appropriate for the convenience of HCPSS.
17. Subcontracting and Assignment.
 - 17.1. The Contractor may not subcontract any portion of the Services provided under this Contract without obtaining the prior written approval of HCPSS nor may the Contractor assign this Contract or any of its rights or obligations hereunder, without the prior written approval of HCPSS. HCPSS shall not be responsible for the fulfillment of the Contractor's obligations to subcontractors. Any such subcontract shall be subject to any terms and conditions that HCPSS deems necessary to protect its interests. Contractor shall remain responsible for performance of all Services under this Contract and shall be subject to liability to HCPSS for acts and omissions of subcontractors.
 - 17.2. Neither party may assign this Contract without the prior written consent of the other party, which consent shall not be unreasonably withheld, except that Contractor may assign this Contract to any parent, subsidiary, affiliate or purchaser of all or substantially all its assets with notice to HCPSS. Contractor may designate a third party to receive payment without HCPSS's prior written consent unless in conflict with Maryland or federal law, but shall provide HCPSS with notification thereof.
18. Contract Integration and Modification. This Contract and the documents incorporated herein form the entire agreement of the parties with respect to the subject matter of this procurement, and supersede all prior negotiations, agreements and understandings with respect thereto. This Contract may be amended with the written consent of both parties. Amendments may not significantly change the scope of the Contract.
19. No Third-Party Beneficiaries. This Agreement is only for the benefit of the undersigned parties and their permitted successors and assigns. No one shall be deemed to be a third-party beneficiary of this Agreement.

20. Notices. Notices under this Contract will be written and will be considered effective upon personal delivery to the person addressed.
21. Retention of Records. Contractor shall retain and maintain all records and documents relating to this Contract for three years after final payment and will make them available for inspection and audit by authorized representatives of HCPSS, including the Purchasing Office or designee, at all reasonable times.
22. Contingent Fee Prohibition. The Contractor warrants that it has not employed or retained any person, partnership, corporation, or other entity, other than a bona fide employee or agent working for the Contractor, to solicit or secure this Contract, and that it has not paid or agreed to pay any person, partnership, corporation, or other entity, other than a bona fide employee or agent, any fee or any other consideration contingent on the making of this Contract.
23. Compliance with Laws. The Contractor hereby represents and warrants that:
 - 23.1. It is qualified to do business in the State of Maryland and that it will take such action as, from time to time hereafter, may be necessary to remain so qualified;
 - 23.2. It shall comply with all federal, State, and local laws, regulations, and ordinances applicable to its activities and obligations under this Contract; and
 - 23.3. It shall obtain, at its expense, all licenses, permits, insurance, and governmental approvals, if any, necessary to the performance of its obligations under this Contract.
24. Multi-Year Contracts Contingent Upon Appropriations. If HCPSS fails to appropriate funds or if funds are not otherwise made available for continued performance for any fiscal period of this Contract succeeding the first fiscal period, this Contract shall be canceled automatically as of the beginning of the fiscal year for which funds were not appropriated or otherwise made available; provided, however, that this will not affect either HCPSS's rights or the Contractor's rights under any termination clause in this Contract. The effect of termination of the Contract hereunder will be to discharge both the Contractor and HCPSS from future performance of the Contract, but not from their rights and obligations existing at the time of termination. The Contractor shall be reimbursed for the reasonable value of any nonrecurring costs incurred but not amortized in the price of the Contract. HCPSS shall notify the Contractor as soon as it has knowledge that funds may not be available for the continuation of this Contract for each succeeding fiscal period beyond the first.
25. Network/Data Security. HCPSS is required to assess risks, ensure data integrity, and determine the level of accessibility that shall be maintained when applicable.
 - 25.1. Specific activities include, but are not limited to:
 - 25.1.1. Identification of security, privacy, legal, and other organizational requirements for recovery of institutional resources such as data, software, hardware, configurations, and licenses at the termination of the contract.
 - 25.1.2. Assessment of the contractor's security and privacy controls including HCPSS's security and privacy requirements in the agreement.
 - 25.1.3. Periodic reassessment of contractor services provisioned to ensure all contract obligations are being met and to manage and mitigate risk.
 - 25.2. The Contractor is the owner or authorized user of the Contractor's software and all of its components, and Contractor software and all of its components, to the best of Contractor's knowledge, do not violate any patent, trademark, trade secret, copyright or any other right of ownership of any third party.
 - 25.3. Contractor shall:
 - 25.3.1. Establish and maintain industry standard technical and organizational measures to help to protect against accidental damage to, or destruction, loss, or alteration of the materials;
 - 25.3.2. Establish and maintain industry standard technical and organizational measures to help to protect against unauthorized access to the Services and materials; and
 - 25.3.3. Establish and maintain network and internet security procedures, protocols, security gateways and firewalls with respect to the Services. Contractor software and its components are equipped and/or designed with systems intended to prevent industry known system attacks (e.g., hacker and virus attacks) and unauthorized access to confidential information.

- 25.3.4. Report any confirmed or suspected breach of data to HCPSS within one hour of discovery or detection. Any confirmed or suspected computer security incidents not resulting in breach of HCPSS data shall be reported to HCPSS within 12 hours of discovery or detection.
- 25.3.5. Follow strong identity management characteristics and practices, requiring users to adhere to organizational usage, construction, and change requirements.
- 25.3.6. Configure and maintain network to be suitably hardened against security threats and ensure adequate performance.
- 25.4. HCPSS, at its sole option, may request the Contractor to provide Service Organization Control (SOC) 2, Type 2 reports or equivalent, for all services and facilities from which the services are provided. It is the Contractor's responsibility that such Reports are provided under the terms and conditions of this Contract without HCPSS being required to agree to additional terms and conditions that may be applied by a third party. If a Report states that a facility has failed to materially satisfy one or more control objectives, Contractor will, as HCPSS's sole remedy, use commercially reasonable efforts to cause the facility to materially satisfy all control objectives. If, despite Contractor's efforts, the facility cannot materially satisfy all relevant control objectives, Contractor will mitigate the issue in a commercially reasonable manner which may include the migration to an alternate facility which materially satisfies all control objectives. Failure to do so may be considered a material breach of this Agreement in the sole and reasonable discretion of HCPSS.
- 25.5. HCPSS or an appointed audit firm (Auditors) has the right to audit Contractor and its sub-vendors or affiliates that provide a service for the processing, transport or storage of HCPSS data. Audits will be at HCPSS's sole expense which includes operational charges by Contractor, except where the audit reveals material noncompliance with contract specifications, in which case the cost, inclusive of operational charges by Contractor, will be borne by the Contractor. In lieu of HCPSS or its appointed audit firm performing their own audit, if Contractor has an external audit firm that performs a review, HCPSS has the right to review the controls tested as well as the results and has the right to request additional controls to be added to the certified report for testing the controls that have an impact on its data.
26. Work Hours. Work performed on HCPSS premises shall be performed during HCPSS normal working hours (see HCPSS School Calendar at <http://www.hcpss.org/calendar>).

SECTION 4. SCOPE OF WORK

1. Purpose. The HCPSS Department of Information Technology is soliciting proposals from established professional services firms to provide consulting services related to the replacement of its telecommunications system. This effort is part of a long-term strategy to ensure HCPSS selects a cost-effective telecommunications technology solution that will meet the long-term needs of the school system.
2. Background. HCPSS currently has two types of phone systems: administrative and classroom. The current configuration of these systems, device counts, and other pertinent information are detailed in Attachment A (Current Network Configuration) and Attachment B (Paging System and Device Counts Per Location).
 - 2.1. Administrative: The Administrative system is built using the Nortel Norstar key system that comprises 74 standalone administrative phone systems in operation working behind Verizon Centrex services. Most of these systems have their own voicemail.
 - 2.2. Classroom: The Classroom telephone and paging system is built using Telecenter 5 and Telecenter 21 services that comprises 77 standalone systems.
3. Requirements.
 - 3.1. The Contractor (consultant) shall demonstrate to HCPSS stakeholders that they have a clear understanding of HCPSS's current telecommunications environment, its supporting infrastructure, and systems that are, or may be, integrated with it.
 - 3.2. The Contractor shall provide a complete and comprehensive recommendation for a Telecommunication Solution within three months of contract execution. Failure to submit a complete and comprehensive recommendation within three months will be considered a breach of contract whereupon Contractor may be subject to liquidated damages (see paragraph 3.15).
 - 3.3. The Contractor shall provide a recommendation for a Telecommunication Solution that minimally includes:
 - 3.3.1. Type of VOIP technology
 - 3.3.2. Type of service
 - 3.3.3. System components
 - 3.3.4. Quantities of system components
 - 3.3.5. Specific features recommended for the HCPSS Telecommunication Solution
 - 3.3.6. Specific options that are available to be considered by HCPSS
 - 3.4. The Contractor may recommend multiple solutions. Identify specific advantages and disadvantages of each solution.
 - 3.5. The Contractor's recommended Telecommunication Solution(s) shall have the ability to integrate with existing and future paging, bell, security, fire alarm, and monitoring systems.
 - 3.6. The Contractor's recommended Telecommunication Solution(s) shall include a projected multi-year financial Total Cost of Ownership (TCO) analysis. This shall include, at a minimum, the following costs: hardware, software, maintenance, installation, telecom services, contract services, repair services, and support. Include an Excel spreadsheet.
 - 3.7. The Contractor shall provide architectural design documents that specifically support the proposed solution(s).
 - 3.8. The Contractor shall present the requirements identified above to multiple stakeholders both technical and non-technical. All questions and concerns, verbal or in writing, shall be documented and answered in writing to the satisfaction of stakeholders.
4. RFP Assistance (Optional Requirement). The Offeror shall indicate if they are interested in the creation of Request for Proposal (RFP) requirements, evaluation criteria, and evaluation of submitted responses for the forthcoming telecommunications solution RFP.
5. Technical Requirements. Submittals must demonstrate that the respondent meets specific qualifications. This includes but is not limited to the following:
 - 5.1. Is an established professional services firm.
 - 5.2. Has experience in providing telecommunications subject matter expertise and fiscal analysis to medium-sized and above organizations in the public sector.
 - 5.3. Has the ability to supply experienced personnel to perform the work detailed in this Scope of Work.
 - 5.4. Conducts activities and methodologies in accordance with industry best practices.

6. Account Representative. Identify Account Representative(s) and any other Key People who will be assigned to the HCPSS Contract for the duration of this Contract. No changes in these assignments will be allowed without written authorization from HCPSS via contract amendment prior to such changes being made.

7. Non-Performance of Personnel. In the event that HCPSS is dissatisfied with the Contractor's personnel for not performing, the Contractor personnel may be removed at the HCPSS Program Coordinator's discretion. Replacement personnel must have qualifications equal to or greater than that of the non-performing person initially proposed and evaluated and accepted in the agreement. The HCPSS Program Coordinator will determine the amount of time the Contractor has to provide a replacement.

SECTION 5. EVALUATION CRITERIA

1. Transmittal Letter

A transmittal letter prepared on the Offeror's business stationery shall accompany the Technical Proposal. The letter should be an executive summary that clearly and concisely addresses all of the requirements of this RFP. The letter shall be signed by an individual who is authorized to bind the firm to all statements, including services and financial commitments. Include the Offeror's official business address and state in which it is incorporated or organized. An appropriate contact name, title, phone number, and email address should also be provided for HCPSS's use during the procurement process.

2. Signing of Forms

A Proposal, if submitted by an individual, shall be signed by the individual. If submitted by a partnership, a Proposal shall be signed by such member(s) of the partnership with authority to bind the partnership. If submitted by a corporation, a Proposal shall be signed by an officer, and attested by the corporate secretary or an assistant corporate secretary; if not signed by an officer, there shall be attached a copy of a board resolution or that portion of the by-laws, duly certified by the corporate secretary, showing the authority of the person so signing on behalf of the corporation.

3. Technical Proposal

Clear, concise, yet detailed responses to the technical criteria below are to be provided. Standard sales material may be provided but shall be attached as an Attachment rather than included within the body of the Proposal. Offerors shall insert a page break for each section of the Proposal to separate responses to each of the technical criteria.

The information identified below shall be furnished in the Proposal. Failure to include any of the items listed below may disqualify your firm's response. It is the Offeror's responsibility to tailor its response to demonstrate its qualifications to perform the scope of work specifically for HCPSS.

Offeror's Technical Proposal shall be submitted separate from the PRICE PROPOSAL and clearly identified in its proposal as TECHNICAL PROPOSAL.

- 3.1. Summary: Provide a comprehensive, detailed narrative, including a high-level schedule and project milestones, describing how the Offeror plans to address the technical requirements in the order outlined in Section 4, Scope of Work.
- 3.2. Staffing Qualifications: Provide resumes of staff that will be utilized to provide services as described in Section 4, Scope of Work.
- 3.3. Unique Qualifications: Provide a narrative to elaborate on any special/unique qualifications, expertise, and/or experiences of the Offeror and/or any member of its team, which make it uniquely capable to provide a solution to HCPSS.
- 3.4. Company Profile/Demonstration of Prior Work: The Offeror shall demonstrate and certify that it possesses at a minimum two (2) years of experience providing professional services as described in this document to institutions similar to HCPSS in scale. This includes providing details on company history, number of employees, and number of similar contracts.
- 3.5. References: The Offeror must provide references for a minimum of three contracts of similar size and scope completed, to include contact person's name and telephone number, dates of services, types of personnel supplied, and descriptions of services performed. Work performed for K-12 public school systems of similar size and scope is preferred and will be scored higher. HCPSS reserves the right to verify all information given as well as to check any other sources available, including itself, as a reference by the Offeror.
- 3.6. Account Representative(s): Provide the name and resume of the proposed Account Representative(s) and Key Personnel (if applicable) to be assigned to HCPSS. It is preferred that the proposed Account Representative have at least three (3) years of experience overseeing staffing requirements identified in this RFP. Provide the names of three (3) clients in which the proposed Account Representative held a similar position. Indicate other key personnel that will be assigned to HCPSS and his/her role on the contract.

- 3.7. Signature: Complete and sign the RFP Signature Sheet (Attachment C)
- 3.8. Acknowledge: Compliance with HCPSS Insurance Requirements (Attachment D).
- 3.9. Acknowledge: Compliance with HCPSS Client Data Privacy (Attachment E).
- 3.10. Acknowledge receipt of Addenda Form: If any addenda to the RFP documents are issued prior to the due date and time for Proposals, this form (Attachment F) shall be completed, signed, and included in the Offeror's Proposal.
- 3.11. Proposal Affidavit: Complete and sign the Proposal Affidavit (Attachment G) and enclose with the Technical Proposal.
- 3.12. Acknowledge Review of Contract: The HCPSS Contract for this procurement will contain the provisions in all Terms and Conditions, Attachments, Addenda, presentation and discussion materials as well as any additional terms required by HCPSS. By submitting a Proposal, the Offeror warrants that they have reviewed the Agreement for Professional Services (Attachment H) and will execute a contract with these terms and conditions after award by the Board of Education. For accounting purposes only HCPSS will issue a purchase order to the awarded firm.

SECTION 6. EVALUATION PROCESS

1. Evaluation.
 - 1.1. Following evaluation of the Proposals the Evaluation Committee will make an initial overall ranking of the Proposals and recommend to the Purchasing Office the award of the contract(s) to the Offeror whose Proposal(s) is (are) determined to be the most advantageous to HCPSS. Minor irregularities contained in Proposals, which are immaterial or inconsequential in nature, may be waived wherever it is determined to be in HCPSS's best interest and when permitted by law. The decision of the award(s) of the Contract will be made at the discretion of the Purchasing Office and will depend on the facts and circumstances of the procurement.
 - 1.2. Following the Purchasing Office's qualifying review and approval, the decision for progressing in the procurement process will be made based on the strengths, weaknesses, advantages, and deficiencies that the Proposals represent.
2. Shortlisting. A shortlist may be developed based on the Evaluation results. All Offerors will be notified of the results as they pertain to their respective Proposal.
3. Oral Presentations/Discussion Sessions.
 - 3.1. Purpose: Based on the Evaluation Committee's initial Evaluation, HCPSS may invite, without cost to itself, the shortlisted Offerors to an oral presentation/discussion session ("Discussion Session"). The purposes of the Discussion Session are as follows:
 - 3.1.1. To provide the Offeror the opportunity to demonstrate its experience.
 - 3.1.2. To discuss/clarify any and all aspects of the Technical Proposal, in particular approach/methodologies, implementation process, cost model options, schedule, staffing of the contract, and ongoing support of the Project and other applicable professional services;
 - 3.1.3. To allow HCPSS to meet the Offeror's key personnel and for these personnel to convey directly their experience and expertise; and,
 - 3.1.4. To provide an opportunity to clarify the scope of services for the intended contract and discuss any items addressed in the Technical Proposal that may require additional clarification.
 - 3.2. Format: The Discussion Session will be informal, as HCPSS is not interested in a sales presentation by executives and business development staff; rather, HCPSS is requesting an interactive discussion with each of the shortlisted Offerors and the experienced personnel submitted in their proposals. It is important that those key personnel who are proposed to be assigned to HCPSS fully participate in the presentation and discussion. These individuals may be asked to demonstrate their technical skills so HCPSS can evaluate their knowledge and expertise for the specific position they will fill. Ample time will be available for the HCPSS and the Offeror to ask questions and discuss issues and concerns related to the Project, the scope of the services, and the Offeror's capabilities and qualifications. We anticipate that the Discussion Session will be approximately 90 to 120 minutes in length.
 - 3.3. Information presented or discussed in the Discussion Session may supersede information provided in the initial offer.
 - 3.4. Following the Discussion Session, additional follow-up and/or clarification documentation may be requested of each Offeror.
 - 3.5. Date: The times and dates for the Discussion Session(s) will be set upon completion of the Initial Evaluation. Offerors are advised to set these dates aside in their entirety on the calendars of key personnel identified in their offer.
 - 3.6. Location: The discussion may be onsite at HCPSS, via telephone, or via web conferencing.
4. Best and Final Offers. Following the evaluation and/or Discussion Session, Best and Final Offers may be requested of selected Offerors.

5. Negotiations. HCPSS may select for award one (1) or more Offeror(s) to negotiate the terms and conditions of the Contract. HCPSS reserves the right to make an award with or without negotiation.
6. Basis for Award. Technical merit will have a greater weight than cost in the final ranking. Award may be made to the Offeror with a higher technical ranking even if its Price Proposal is not the lowest. The Purchasing Office retains the discretion to examine all factors to determine the award of the contract. The goal is to contract with the Offeror(s) that would best meet the needs of HCPSS as set forth in the RFP.
7. Price Proposal. Offeror shall respond with pricing, PRICE PROPOSAL, for the Project that meets the requirements described in its technical response.
 - 7.1. Offeror shall provide hourly billing rates and indicate a maximum ceiling for the total cost for services based on the Offeror's understanding of the requirements detailed in Section 4, Scope of Work.
 - 7.2. Option - RFP Assistance: If interested, Offeror shall provide hourly billing rates and indicate a maximum ceiling for the total cost for RFP assistance based on the Offeror's understanding of the requirements detailed in Section 4, Scope of Work, paragraph 4.
 - 7.3. Billing rates offered shall be inclusive of all overhead, profit, travel, accommodations, administrative fees, and direct and indirect costs and shall represent onsite staff work within Howard County, MD. HCPSS will not recognize or accept any separate or additional charges or fees to perform the services identified in this RFP.
 - 7.4. Offeror's PRICE PROPOSAL shall be submitted separate from the TECHNICAL PROPOSAL and clearly identified as PRICE PROPOSAL.

Attachments and Forms (Check List)

Attachment A	Current Network Configuration	
Attachment B	Paging System and Device Counts Per Location	
Attachment C	Signature Sheet	
Attachment D	Insurance Requirements	
Attachment E	Client Data Privacy	
Attachment F	Acknowledgement of Receipt of AddendaForm	
Attachment G	Bid/Proposal Affidavit	
Attachment H	Agreement for Professional Services	

Attachment A Current Network Configuration

High Schools

VLAN 2 – Admin
VLAN 4 – Management
VLAN 6 – Student
VLAN 20 – Wireless Pvt
VLAN 21 – Bldg Maint
VLAN 22 – Video
VLAN 23 – Guest

To CO 6509_I
G G I 0/1-6
ICBN
5 GB LAG

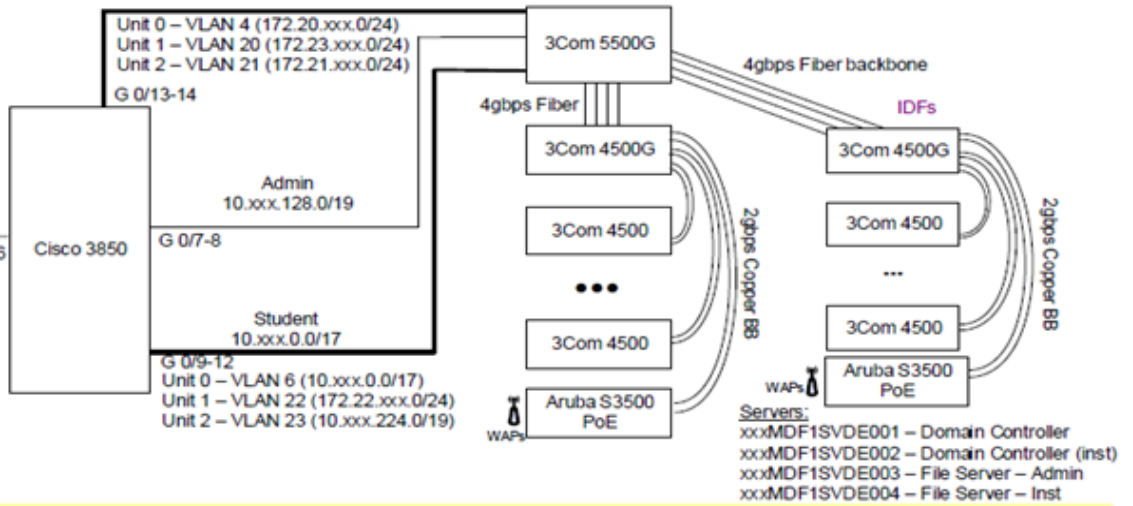

Elementary & Middle Schools

VLAN 2 – Admin
VLAN 4 – Management
VLAN 6 – Student
VLAN 20 – Wireless Pvt
VLAN 21 – Bldg Maint
VLAN 22 – Video
VLAN 23 – Guest

To CO 6509
G 0/0
ICBN
3GB LAG MS
1GB ES

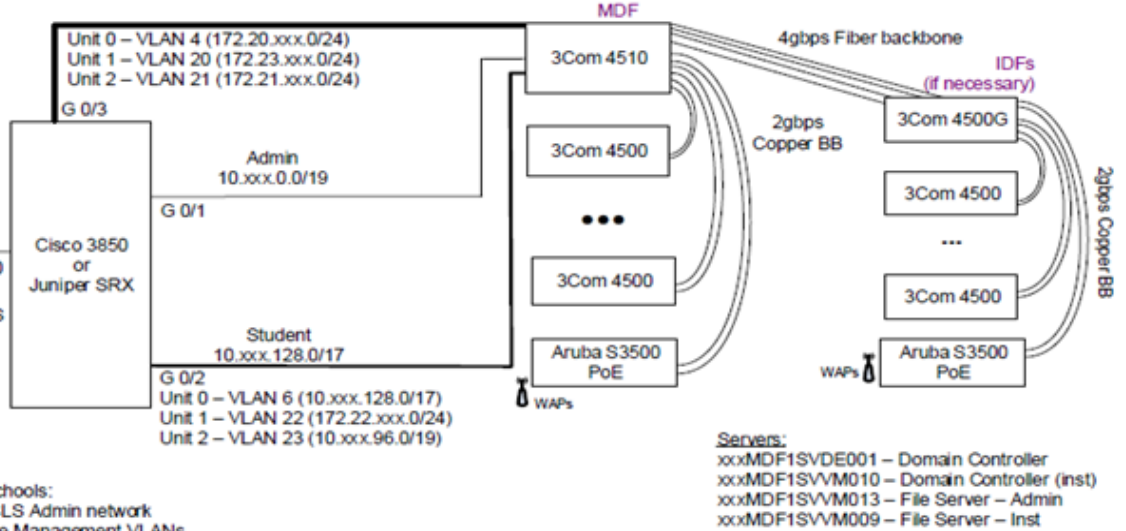

Router Configurations:

Identical except in the following schools:

- LKMS has a static route to CLS Admin network
- HaES and CRES do not have Management VLANs

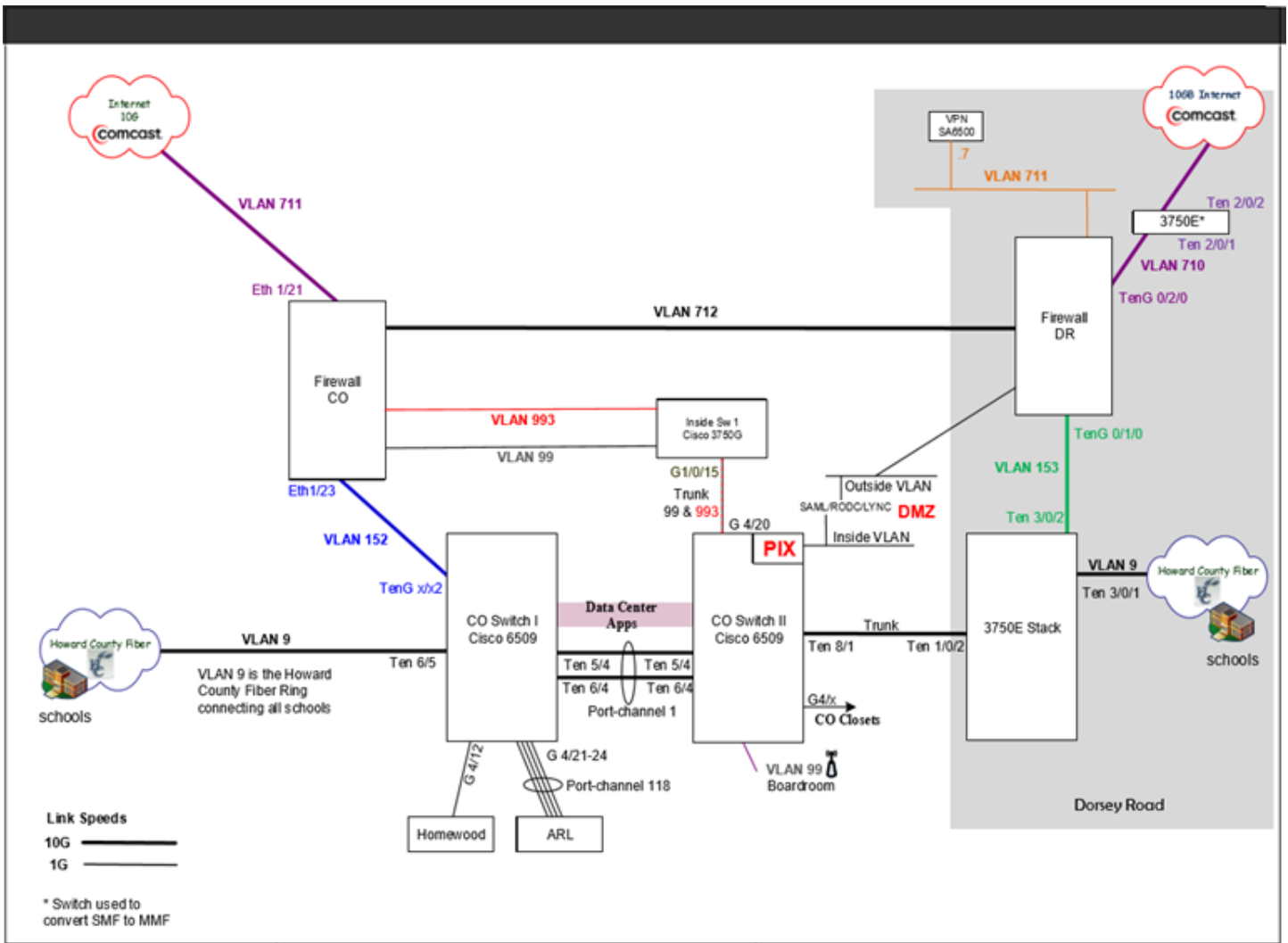

Attachment B
Paging System and Device Counts Per Location

#	Elementary	Ports	Phones	Manufacturer	SYSTEM	Year Installed	Current Production
1	Atholton	81	63	Rauland	TC21	2001-2002	END 2017
2	Bellows Spring	144	89	Rauland	TC21	2003	END 2017
3	Bollman Bridge	144	74	Rauland	TC21	2001-2014	END 2017
4	Bryant Woods	80	68	Rauland	TC21	2001-2002	END 2017
5	Bushy Park	128	92	Rauland	TC21	2007	END 2017
6	Centennial Lane	128	86	Rauland	TC21	2001-2002	END 2017
7	Clarksville	80	59	Rauland	TC21	2001-2002	END 2017
8	Clemens Crossing	128	83	Rauland	TC21	2001-2002	END 2017
9	Cradlerock	96	73	Rauland	TC21	2002	END 2017
10	Dayton Oaks	128	95	Rauland	TC21	2006	END 2017
11	Deep Run	112	99	Rauland	TC21	2001-2002	END 2017
12	Ducketts Lane	112	84	Rauland	TC21	2013	END 2017
13	Elkridge	128	96	Rauland	TC21	2001-2002	END 2017
14	Forest Ridge	112	98	Rauland	TC21	2001-2002	END 2017
15	Fulton	143	74	Rauland	TC V	1998	NO
16	Gorman Crossing	154	90	Rauland	TC V	1998	NO
17	Guilford	96	80	Rauland	TC21	2001-2002	END 2017
18	Hammond	80	46	Rauland	TC21	2001-2002	END 2017
19	Hollifield Station	119	81	Rauland	TC V	1997	NO
20	Ilchester	124	86	Rauland	TC V	1996	NO
21	Jeffers Hill	80	50	Rauland	TC21	2001-2002	END 2017
22	Laurel Woods	80	70	Rauland	TC21	2001-2002	END 2017
23	Lisbon	96	75	Rauland	TC21	2001-2002	END 2017
24	Longfellow	112	82	Rauland	TC21	2001-2017	END 2017
25	Manor Woods	125	73	Rauland	TC V	1994	NO
26	Hanover Hills			Rauland	TC21	2018	

#	Elementary	Ports	Phones	Manufacturer	SYSTEM	Year Installed	Current Production
27	Northfield	112	48	Rauland	TC21	2001 2014	END 2017
28	Phelps Luck	112	96	Rauland	TC21	2001 2015	END 2017
29	Pointers Run	112	98	Rauland	TC21	2001- 2002	END 2017
30	Rockburn	103	88	Rauland	TC V	1993	NO
31	Running Brook	96	80	Rauland	TC21	2001- 2013	END 2017
32	St. John's Lane	128	78	Rauland	TC21	2000	END 2017
33	Stevens Forest	112	62	Rauland	TC21	2015	END 2017
34	Swansfield	96	72	Bogen			
35	Talbott Springs	80	75	Rauland	TC21	1999	END 2017
36	Thunder Hill	96	77	Rauland	TC21	2001 2002	END 2017
37	Triadelphia Ridge	115	77	Rauland	TC V	1998	NO
38	Veterans	144	82	Rauland	TC21	2007	END 2017
39	Waterloo	160	91	Rauland	TC21	2001 2002	END 2017
40	Waverly	96	72	Bogen			
41	West Friend	80	57	Rauland	TC21	2001 2002	END 2017
42	Worthington	128	88	Rauland	TC21	2001 2002	END 2017
	Elem. Total	4580	3207				
	Middle						
1	Bonnie Branch	107	76	Rauland	TC V	1999	NO
2	Burleigh Manor	128	88	Rauland	TC21	2001 2002	END 2017
3	Clarksville	112	82	Rauland	TC21	2001 2002	END 2017
4	Dunloggin	80	78	Rauland	TC21	1999	END 2017
5	Elkridge Landing	159	117	Rauland	TC V	1995	NO
6	Ellicott Mills	144	115	Rauland	TC21	1999	END 2017
7	Folly Quarter	112	85	Rauland	TC21	2003	END 2017
8	Glenwood	112	72	Rauland	TC21	1999	END 2017
9	Hammond	112	80	Rauland	TC21	2001 2002	END 2017
10	Harper's Choice	80	72	Rauland	TC21	1999	END 2017
11	Lake Elkhorn	96	67	Rauland	TC21	2002	END 2017

#	Elementary	Ports	Phones	Manufacturer	SYSTEM	Year Installed	Current Production
12	Lime Kiln	110	80	Rauland	TC V	1999	NO
13	Mayfield Woods	128	102	Rauland	TC21	2002	END2017
14	Mount View	223	102	Rauland	TC V	1993	NO
15	Murray Hill	114	71	Rauland	TC V	1997	NO
16	Oakland Mills	128	80	Rauland	TC21	2001 2002	END 2017
17	Patapsco	160	105	Rauland	TC21	2001 2002	END 2017
18	PVMS REN			Care Hawk 1000	1000	2017	YES
19	Patuxent Valley	144	94	Bogen			
20	New Wilde Lake			Bogen		2017	
21	Wilde Lake	128	72	Bogen			
22	TVMS	112	105	Rauland	TC21	2015	END 2017
	Middle Total	2489	1743				
	High						
1	Atholton	256	182	Rauland	TC21	2015	END 2017
2	Centennial	208	174	Rauland	TC21	2000	END 2017
3	Glenelg	192	153	Rauland	TC21	1999	END 2017
4	Hammond	192	174	Rauland	TC21	1999	END 2017
5	Howard	256	183	Rauland	TC21	1999	END 2017
6	Long Reach	195	132	Rauland	TC V	1995	NO
7	Marriotts Ridge	256	155	Rauland	TC21	2005	END 2017
8	Mt. Hebron	208	166	Rauland	TC21	2014	END 2017
9	Oakland Mills	224	174	Rauland	TC21	2001 2002	END 2017
10	Reservoir	256	226	Rauland	TC21	2002	END 2017
11	River Hill	191	148	Rauland	TC V	1994	NO
12	Wilde Lake	239	165	Rauland	TC V	1996	NO
	High Total	2673	2032				
	Special						
1	ARL	176	100	Rauland	TC21		END 2017
2	Homewood	144	122	Rauland	TC21		END 2017
3	Cedar Lane	96	71	Rauland	TC21		END 2017
	Spec. Total	416	293				
	Grand Total	1015 8	7275				

ATTACHMENT C

Signature Sheet

A. Proposer's Certification

I/we hereby propose to furnish and deliver supplies and or services, in accordance with specifications and stipulations contained herein, and at the prices quoted. I/we certify that this bid is made without any previous understanding, agreement, or connection with any person, firm, or corporation making a bid for the same supplies, materials, or Lumber and is in all respects fair and without collusion or fraud.

I/we certify that this bid is made without having contacted any employee within The Howard County Public School System unless such contacts were previously authorized by the Purchasing Officer.

I/we certify that this bid is genuine and not collusive or sham; that said Proposer has not colluded, conspired, connived and agreed, directly or indirectly, with any Proposer or person to put in a sham bid or to refrain from bidding and is not in any manner, directly or indirectly, sought by agreement of collusion or communication or conference, with any person to fix the bid prices of the affidavit or any other Proposer, or to fix any overhead, profit or cost element of said bid price, or that of any Proposer, or to secure any advantage against the Board of Education of Howard County or any other person interested in the proposed contract; and that all statements in said proposal or bid are true.

I affirm that this firm will not knowingly employ an individual to work at a school if the individual is a Registered Sexual Offender, pursuant to section 11-722 (C) of the Criminal Procedure Article of the Annotate Code of Maryland. A firm or person who violates this section is guilty of a misdemeanor and on conviction is subject to imprisonment not exceeding 5 years or a fine not exceeding \$5,000 or both.

I hereby certify that I am authorized to sign for the Proposer.

B. Disqualification - Bribery

A person convicted for bribery, attempted bribery, or conspiracy to bribe shall be disqualified from entering into a contract with any county or other subdivision of the state. Every business entity upon submitting a bid or otherwise applying for a contract shall submit an affidavit stating whether it, its officers, directors, or partners, or its employees have been convicted of bribery, attempted bribery, or conspiracy to bribe under the laws of any state or federal government.

Submitted by:

(company name)

(street address)

(city, state and zip)

(company telephone number)

(name of person authorized to sign bid)

(title of authorized representative)

(signature of authorized representative)

(Date)

(e-mail of authorized representative)

(telephone number of representative)

ATTACHMENT D

INSURANCE REQUIREMENTS

1 - General Insurance Requirements:

1.1 - The Contractor shall not commence Work until he has obtained at his own expense all of the insurance as required hereunder and such insurance has been approved by the Board of Education of Howard County Maryland; nor shall the Contractor allow any Subcontractor to commence Work on his subcontract until all similar insurance required of the Subcontractor has been so obtained and approved by the Contractor. Approval of insurance required of the Contractor will be granted only after submission to the Board of Education of Howard County Maryland of original, signed certificates of insurance or, alternately, at the Board of Education of Howard County Maryland's request, certified copies of the required insurance policies.

1.2 - The Contractor shall require all Subcontractors to maintain during the term of this agreement, commercial general liability insurance, business automobile liability insurance, and Workers' Compensation and employers' liability insurance, in the same manner as specified for the Contractor. The Contractor shall furnish Subcontractors' certificates of insurance to the Board of Education of Howard County Maryland immediately upon request.

1.3 - All insurance required hereunder shall include the following provision: "It is agreed that this policy is not subject to cancellation, non-renewal, material change, or reduction in coverage until sixty (60) days prior written notice has been given to the Board of Education of Howard County Maryland."

The phrases "endeavor to" and "... but failure to mail such notice shall impose no obligation or liability of any kind upon the company, its agents or representatives" are to be eliminated from the cancellation provision of standard ACORD certificates of insurance.

1.4 - No acceptance and/or approval of any insurance by the Board of Education of Howard County Maryland shall be construed as relieving or excusing the Contractor, or the Surety, or his bonds, from any liability or obligation imposed upon either or both of them by the provisions of the Contract Documents.

1.5 - The Board of Education of Howard County Maryland and its elected or appointed officials, agents and employees are to be named as an additional insured under all coverages except Workers compensation and business automobile liability, and the certificate of insurance, or the certified policy, if requested, shall so state this. Coverage afforded under this paragraph shall be primary as respects the Board of Education of Howard County Maryland, its agents and employees.

1.6 - The Contractor shall be responsible for the Work performed under the Contract Documents and every part thereof, and for all materials, tools, equipment, appliances, and property of any and all description used in connection with the Work. The Contractor assumes all risk for direct and indirect damage or injury to the property or persons used or employed on or in connection with the Work contracted for, and of all damage or injury to any person or property wherever located, resulting from the action, omission, commission or operation under the contract, or in connection in any way whatsoever with the contracted Work, until final acceptance of the Work by the Board of Education of Howard County Maryland.

1.7 - Insurance coverage required in these specifications shall be in force throughout the contract term. Should the Contractor fail to provide acceptable evidence of current insurance within seven days of written notice at any time during the contract term, the Board of Education of Howard County Maryland shall have the absolute right to terminate the contract without any further obligation to the Contractor, and the Contractor shall be liable to the Board of Education of Howard County Maryland for the entire additional cost of procuring performance and the cost of performing the incomplete portion of the contract at time of termination.

1.8 - Contractual and other liability insurance provided under this contract shall not contain a supervision, inspection or engineering services exclusion that would preclude the Board of Education of Howard County Maryland from supervising or inspecting the project as to the end result. The Contractor shall assume all on-the-job responsibilities as to the control of persons directly employed by it and of the Subcontractors and any persons employed by the Subcontractor.

1.9 - Nothing contained in the specifications shall be construed as creating any contractual relationship between any Subcontractor and the Board of Education of Howard County Maryland. The Contractor shall be fully responsible to the Board of Education of Howard County Maryland for the acts and omissions of the Subcontractors and of persons employed by them as it is for acts and omissions of persons directly employed by it.

1.10 - Precaution shall be exercised by the Contractor at all times for the protection of persons, (including employees) and property. All existing structures, utilities, roads, services, trees and shrubbery shall be protected against damage or interruption of service at all times by the Contractor and its Subcontractors during the term of the contract, and the Contractor shall be held responsible for any damage to property occurring by reason of its operation on the property.

1.11 - If the Contractor does not meet the insurance requirements of the specifications, alternate insurance coverage, satisfactory to the Board of Education of Howard County Maryland, may be considered. Written requests for consideration of alternate coverages shall be received by the Board of Education of Howard County Maryland at least ten Working days prior to the date set for receipt of bids or proposals. If the Board of Education of Howard County Maryland denies the request for alternate coverages, the specified coverages will be required to be submitted.

1.12 - All required insurance coverages shall be acquired from insurers allowed to do business in the State of Maryland and acceptable to the Board of Education of Howard County Maryland. The insurers shall also have a policyholders' rating of "A-" or better, and a financial size of "Class VII" or better in the latest edition of Best's Insurance Reports, unless the Board of Education of Howard County Maryland grants specific approval for an exception.

1.13 - The Board of Education of Howard County Maryland will consider any deductible amounts as part of its review of the financial stability the Contractor. Any deductibles shall be disclosed by the Contractor, and deductible amounts are the responsibility of the Contractor.

2 - Contractor's Liability Insurance - "Occurrence" Basis:

2.1 - The Contractor shall purchase the following insurance coverages:

2.1.1 - Commercial general liability with a minimum limit of \$1,000,000 per occurrence, \$1,000,000 annual aggregate including all of the following:

- i. General aggregate limit is to apply per project;
- ii. Premises/operations;
- iii. Actions of independent Contractors;
- iv. Products/completed operations to be maintained for two years after completion of the Work;
- v. Contractual liability including protection for the Contractor from claims arising out of liability assumed under this contract;
- vi. Personal injury liability including coverage for offenses related to employment;
- vii. Explosion, collapse, or underground (XCU) hazards (confirmation of underground hazard coverage shall be confirmed by either certificate of insurance or in writing by Contractor's agent, broker or insurer);

2.1.2 - Business automobile liability including coverage for any owned, hired, or non-owned motor vehicles and automobile contractual liability with a limit of \$1,000,000 per accident; uninsured motorist coverage at minimum statutory limits.

2.1.3 - Workers compensation with statutory benefits as required by Maryland law or the U. S. Longshoremen's and Harbor Workers' Compensation Act, or other laws as required by labor union agreements, including standard other states coverage; employers' liability coverage with limits of \$100,000 per accident, \$100,000 per employee for disease, and a \$500,000 disease policy limit.

2.1.4 - Total limit requirements of 2.1.1, 2.1.2 and 2.1.3 may be met by a combination of primary and umbrella excess liability coverage.

2.1.5 - Aircraft liability including coverage for any owned, hired or non-owned aircraft utilized in the project (e.g. installation of HVAC unit on school roof) with a minimum limit of \$ NA per occurrence applicable to aircraft while in flight or in motion. A higher limit may be required by the Board of Education of Howard County Maryland upon exposure review.

3 - Commercial General or Other Required Liability Insurance - "Claims Made "Basis

3.1 - If commercial general or other liability insurance purchased by the Contractor has been issued on a "claims made" basis, the Contractor shall comply with the following additional conditions:

- i. Agree to provide certificates of insurance evidencing the above coverages for a period of two years after final payment for the contract. Such certificates shall evidence a retroactive date, no later than the beginning of the Contractors' or Subcontractors' Work under this contract, or
- ii. Purchase an extended (minimum two years) reporting period endorsement for the policy or policies in force during the term of this contract and evidence the purchase of this extended reporting period endorsement by means of a certificate of insurance or a copy of the endorsement itself.

ATTACHMENT E

Client Data Privacy

HCPSS, as a Government entity, is required when entering into agreements with other parties to follow all applicable laws and regulations, including those related to data privacy and security; accessibility; and records retention. Accordingly, the Terms of Service (TOS) are hereby modified by this Amendment as they pertain to HCPSS's use of the Company's Site and/or Services.

- A. **Definition of "CLIENT Data"**: CLIENT Data include all Personally Identifiable Information (PII) and other non-public information. CLIENT Data include, but are not limited to, student data, metadata, and user content.
- B. **Data Collection and Use**: ENTITY will collect and use CLIENT Data only for the purpose of fulfilling its duties and providing services under this Agreement, and for improving services under this Agreement.
- C. **Education Records**: If ENTITY will have access to "education records" as defined under the Family Educational Rights and Privacy Act (FERPA) (34 CFR Part 99), the ENTITY acknowledges that for the purpose of this Agreement it will be designated as a 'school official' with 'legitimate educational interests' and will use the data only for the purpose of fulfilling its duties under this Agreement. ENTITY agrees to indemnify and hold harmless the Board of Education of Howard County for any damages or costs, including reasonable attorney's fees, which arise out of any gross negligence or willful misconduct by ENTITY, its agents and employees concerning its FERPA obligations under this section.
- D. **Obligation of Confidentiality**: In performing services under this Agreement, ENTITY and CLIENT may be exposed to and will be required to use certain "Confidential Information", as defined below. ENTITY and CLIENT along with their employees, agents or representatives will not, use, directly or indirectly, such Confidential Information for purposes other than the purposes outlined in this Agreement.
- E. **Definition of Confidential Information**: "Confidential Information" means information, not generally known, and proprietary to the ENTITY or CLIENT or to a third party for whom the ENTITY or CLIENT is performing work, including, without limitation, information concerning any patents or trade secrets, confidential or secret designs, processes, formulae, source codes, plans, devices or material, research and development, proprietary software, analysis, techniques, materials or designs (whether or not patented or patentable), directly or indirectly useful in any aspect of the business of the ENTITY or CLIENT. Confidential Information includes all information which ENTITY or CLIENT acquires or becomes acquainted with during the period of this Agreement, whether developed by ENTITY, CLIENT or others, which ENTITY or CLIENT has a reasonable basis to believe to be Confidential, such as data that is personally identifiable to an individual student and information within the definition of "Education Record." The parties agree that the following will be treated as "Confidential Information": (i) all database information ("Data") provided by or on behalf of CLIENT to ENTITY; (ii) all information provided by ENTITY to CLIENT pertaining to the Services; (iii) all information which is labeled as such in writing and prominently marked as "Confidential," "Proprietary" or words of similar meaning by either party; or (iv) business information of a party which a reasonable person would understand under the circumstances to be confidential.
- F. **Maintenance of Confidentiality**: Any Confidential Information acquired or received by either party (the "Recipient") in the course of this Agreement will not be disclosed or transferred to any person or entity other than to employees of a party and, as to ENTITY, for the purpose of performing its obligations under this Agreement. Confidential Information received under this Agreement will be treated with the same degree of care and security as each party uses with respect to its own Confidential Information, but not less than a reasonable degree of care. The parties agree to use Confidential Information only for the purpose of performance of this Agreement and to make no copies except as necessary for performance of this Agreement. Any such confidential information and copies thereof made by a party, or any representative of a party, shall be completely and promptly destroyed at the conclusion of contract performance subject to paragraph F.1 below.
 - 1. Upon termination or completion of the Services hereunder, upon request of CLIENT, ENTITY will delete the CLIENT's Confidential Information as housed in the ENTITY production database(s), provided that ENTITY may maintain archival copies for audit purposes and dispute resolution purposes and ENTITY may retain copies of Confidential Information on back-up media in which such Data is co-resident with other employment and income data. ENTITY shall remain under its contractual obligation of confidentiality and security to CLIENT and such obligations shall survive

termination of the Agreement. This Section shall survive the termination of this Agreement.

- G. **Data De-Identification:** ENTITY may use de-identified Data for product development, research, or other internal purposes. De-identified Data will have all direct and indirect personal identifiers removed. This includes, but is not limited to, name, ID numbers, date of birth, demographic information, location information, and school ID. Furthermore, ENTITY agrees not to attempt to re-identify de-identified Data.
- H. **Data Mining, Marketing and Advertising:** Except as indicated in Section G above, ENTITY is prohibited from mining CLIENT Data for any purposes other than those agreed to by the parties. **Data mining or scanning of user content for the purpose of advertising or marketing to students or their parents is prohibited. Any and all forms of advertisement, directed towards children, parents, guardians, or District Employees will be strictly prohibited unless allowed with express written consent of the District.**
- I. **Modification of Terms of Service:** ENTITY will not change how CLIENT Data are collected, used, or shared under the terms of this Agreement in any way without advance notice to the CLIENT. This Agreement is the entire agreement between the CLIENT (including all District end users) and the ENTITY. All other agreements or understandings, whether electronic, click-through, verbal or in writing, with District Employees or other End Users shall be null and void.
- J. **Data Sharing:** ENTITY will not share CLIENT data, with or disclose it to any third party, except to affiliated subcontractors, agents, or third-party service providers of the ENTITY, without prior specific and informed written consent of the CLIENT, except as required by law.
- K. **Data Storage:** CLIENT Data will not be stored outside of the United States without prior, specific and informed written consent from the CLIENT.
- L. **Terms, Data Transfer, Survival and Destruction:** The CLIENT may immediately terminate the Agreement if the CLIENT determines the ENTITY has breached this Agreement. The Agreement will automatically terminate at the expiration date. However, the ENTITY's obligations shall survive termination of this Agreement until ALL CLIENT Data has been returned and/or securely removed or destroyed. ENTITY will ensure that all Data in its possession and in the possession of any subcontractors, or agents to which the ENTITY may have transferred Data, are destroyed.
- M. **Rights and License in and to Data:** All goods, products, materials, documents, reports, writings, video images, photographs, papers and intellectual property of any nature including software or computer images prepared by the ENTITY (or subcontractors) for the CLIENT or from CLIENT-provided material will not be disclosed to any other person or entity and remains the property of the school system. All student-produced work remains the property of the school system or that eligible student. The ENTITY has a limited, nonexclusive license to the data described herein solely for the purpose of performing its obligations as outlined in the Agreement. This Agreement does not give ENTITY any rights, implied or otherwise, to Data, content, or intellectual property, except as expressly stated in the Agreement, including any right to sell or trade Data.
- N. **Access:** Except as otherwise expressly prohibited by law, the ENTITY will immediately notify the CLIENT of any subpoenas, warrants, or other legal orders, demands or requests, including Audits, and governmental requests and demands, received by the ENTITY seeking CLIENT Data. If the CLIENT receives a similar request, the ENTITY will promptly supply the CLIENT with copies of records or information required by the CLIENT to respond.
- O. **Security Controls and Risk Management:** ENTITY will store and process CLIENT Data in accordance with industry best practices. This includes appropriate administrative, physical, and technical safeguards to: 1) ensure the security and confidentiality of PII and Confidential Information; 2) protect against any anticipated threats or hazards to the security or integrity of Confidential Information; 3) protect against unauthorized access to or use of Confidential Information that could result in substantial harm or inconvenience to any customer or to any client employee and/or student; and 4) dispose of PII and Confidential Information in a secure manner.
 - 1. To comply with the safeguard obligations generally described above, ENTITY has (a) designated an employee to coordinate its information security program, (b) identified reasonably foreseeable internal and external risks to the security, confidentiality, and integrity of CLIENT Information that could result in the unauthorized disclosure, misuse, alteration, destruction, or other compromise of such information, and assessed the sufficiency of any safeguards in place to control these risks, and (c) designed and implemented information safeguards to control the risks identified through the risk assessment, and regularly tests or otherwise monitors the effectiveness of safeguards'

key controls, systems and procedures.

2. ENTITY will conduct periodic risk assessments and remediate any identified security vulnerabilities in a timely manner. ENTITY will also have a written incident response plan, to include prompt notification of HCPSS in the event of a security or privacy incident, as well as best practices for responding to a breach of PII.
- P. **Data Breaches:** ENTITY shall notify CLIENT in writing as soon as commercially practicable, however no later than forty-eight (48) hours, after ENTITY has either actual or constructive knowledge of a breach which affects CLIENT's Data (an "Incident") unless it is determined by law enforcement that such notification would impede or delay their investigation. ENTITY shall have actual or constructive knowledge of an Incident if ENTITY actually knows there has been an Incident or if ENTITY has reasonable basis in facts or circumstances, whether acts or omissions, for its belief that an Incident has occurred. The notification required by this section shall be made as soon as commercially practicable after the law enforcement agency determines that notification will not impede or compromise the investigation. ENTITY shall cooperate with law enforcement in accordance with applicable law provided however, that such cooperation shall not result in or cause an undue delay to remediation of the Incident. ENTITY shall promptly take appropriate action to mitigate such risk or potential problem at ENTITY's expense. In the event of an Incident, ENTITY shall, at its sole cost and expense, restore the Confidential Information, to as close its original state as practical, including, without limitation any and all Data, and institute appropriate measures to prevent any recurrence of the problem as soon as is commercially practicable.
- Q. **Employee and Subcontractor Qualifications:** ENTITY shall ensure that its employees and all subcontractors who have potential access to CLIENT Data have undergone appropriate background screening and possess all needed qualifications to comply with the terms of this Agreement. Further, all employees and subcontractors are subject to the same FERPA compliance in relation to the 'school official' designation, and should receive training that the re-disclosure of PII and/or Confidential Information will violate federal and state laws and may result in criminal and/or civil penalties.
- R. **Governing Law:** This agreement shall be governed by and construed in accordance with the laws of Maryland, excluding its choice of law rules. Any action or proceeding seeking any relief under or with respect to this Agreement shall be brought solely in the appropriate Maryland Court. ENTITY will comply with Maryland Education Code ANN. § 4-131, "Operators of School Internet Web sites, Online Services, Online Applications, and Mobile Applications." ENTITY agrees to be bound as an "operator" under the law regardless of the ENTITY's exemptions that may exist in Maryland Education Code ANN. § 4-131(a)(3).
- S. **Compliance:** In addition to complying with FERPA and the Maryland Education Code cited above, the ENTITY shall ensure that its products and services comply with the Federal Protection of Pupil Rights Act (34 CFR Part 98), the Federal Children's Internet Protection Act (47 CFR 54.520), and the Federal Children's Online Privacy and Protection Act (16 CFR Part 312).
- T. **Monitoring:** The ENTITY agrees to allow the HCPSS the ability to audit the ENTITY's use of HCPSS data to ensure compliance with the terms of this agreement.
- U. **Indemnification:** ENTITY agrees to indemnify and hold harmless HCPSS, and its members, trustees, employees, agents, officers, and officials, from and against any and all liabilities, taxes, tax penalties, interest, losses, penalties, damages, and expenses of any kind, nature, or character, including costs and attorney fees, arising out of or relating to any and all claims, liens, damages, obligations, actions, suits, judgments, settlements, or causes of action of every kind, nature, or character, in connection with or arising out of the acts or omissions of either Party or its employees, subcontractors, or agents under this Agreement. This provision expressly applies to, but is not limited in application to, matters and circumstances involving or implicating the unauthorized use of any trade secrets, or United States patent or copyright infringement or any liability resulting from the unauthorized disclosure of PII or Confidential Information or a breach of the obligations contained in this Data Sharing Agreement, including those set forth in paragraph R above. The indemnities set forth herein will survive the expiration or termination of this Agreement.

HCPSS agrees to indemnify and hold harmless ENTITY, and its members, trustees, employees, agents, officers, and officials, from and against any and all liabilities, taxes, tax penalties, interest, losses, penalties, damages, and expenses of any kind, nature, or character, including costs and attorney fees, arising out of or relating to any and all claims, liens, damages, obligations, actions, suits, judgments, settlements, or causes of action of every kind, nature, or character, arising out of the intentional or malicious acts of HCPSS or its employees, subcontractors, or agents under this Agreement. This provision expressly applies to, but is not limited in application to, matters and circumstances involving or implicating the unauthorized use of any trade secrets, or United States patent or copyright infringement or any liability resulting from the unauthorized disclosure of PII or Confidential Information or a breach of the obligations contained in this Data Sharing Agreement. The indemnities set forth herein will survive the expiration or termination of this Agreement.

ATTACHMENT F

Acknowledgement of Receipt Of Addenda Form

BID/RFP NO. _____

FOR _____

DUE DATE: _____

NAME OF COMPANY:

ACKNOWLEDGEMENT OF RECEIPT OF ADDENDA

The undersigned hereby acknowledges the receipt of the following addenda:

Addendum No. _____ dated _____

Addendum No. _____ dated _____

Addendum No. _____ dated _____

Addendum No. _____ dated _____

Signature

Printed Name

Title

ATTACHMENT G

BID/PROPOSAL AFFIDAVIT

Date: _____

ACKNOWLEDGEMENT OF MBE AFFIRMATION ACTION REQUIREMENTS

The undersigned acknowledges that this project has a goal of actively attempting to achieve a minimum of twenty-five percent (25%) of the value of this contract for all materials, supplies, equipment and services directly or indirectly from Minority Business Enterprises. The undersigned shall complete the "Minority Business Enterprises Utilization Affidavit" and other related requirements in accordance with the bid specifications.

AFFIDAVIT

Special Instructions: An authorized representative of the bidder shall complete the following affidavit in accordance with these bid documents and insert answer to paragraphs 1 and 3.

Statutory Affidavit and Non-Collusion Certification

I, _____, being duly sworn, depose and state:

1. **I am the _____ (officer) and duly authorized representative of the firm named _____ whose address is _____ and that I possess the authority to make this affidavit and certification on behalf of myself and the firm for which I am acting.**
2. Except as described in Paragraph 3 below, neither I, nor to the best of my knowledge, the above firm, nor any of its officers, directors, or partners, employees, agents, or employees of agents who are directly involved in obtaining or performing contracts with any public bodies has:
 - (a.) Been convicted of bribery, attempted bribery, or conspiracy to bribe, under the laws of any state of the federal government;
 - (b.) Been convicted under the laws of the state, another state, or the United States of: a criminal offense incident to obtaining, attempting to obtain, or performing a public or private contract; or fraud, embezzlement, theft, forgery, falsification or destruction of records, or receiving stolen property;
 - (c.) Been convicted of a criminal violation of an antitrust statute of the State of Maryland, another state, or the United States;
 - (d.) Been convicted of a violation of the Racketeer Influenced and Corrupt Organization Act, or the Mail Fraud Act, for acts in connection with the submission of bids or proposals for a public or private contract;
 - (e.) Been convicted of any felony offenses connected with obtaining, holding, or maintaining a minority business enterprise certification, as prohibited by Section 14-308 of the State Finance and Procurement Article;
 - (f.) Been convicted of conspiracy to commit any act or omission that would constitute grounds for conviction under any of the laws or statutes described in Paragraph (a) through (e) above; or
 - (g.) Been found civilly liable under an antitrust statute of this State, another state, or the United States for acts or omissions in connection with the submission of bids or proposals for a public or private contract.
3. **The only conviction, plea, or admission by any officer, director, partner, or employee of this firm to involvement in any of the conduct described in Paragraph 2 above is as follows:**

If none, write "None" below. If involvement, list the date, count, or charge, official or administrative body, the individuals, their position with the firm and the sentence or disposition of the charge.

(you may attach an explanation as necessary)

- 4. I affirm that this firm will not knowingly enter into a contract with a public body under which a person or business debarred or suspended under Maryland State Finance and Procurement Title 16, subtitle 3, Annotated Code of Maryland, as amended, will provide, directly or indirectly, supplies, services, architectural services, construction-related services, leases of real property, or construction.
- 5. I affirm that this proposal or bid to the Board of Education of Howard County Maryland is genuine and not collusive or a sham; that said bidder has not colluded, conspired, connived and agreed, directly or indirectly, with any bidder or person to put in a sham bid or to refrain from bidding and is not in any manner, directly or indirectly, sought by agreement of collusion or communication or conference, with any person to fix the bid prices of the affidavit or any other bidder, or to fix any overhead, profit or cost element of said bid price, or that if any bidder, or to secure an advantage against the Board of Education of Howard County Maryland or any other person interested in the proposed contract; and that all statements in the proposal or bid are true. I acknowledge that, if the representations set forth in this affidavit are not true and correct, the Board of Education of Howard County Maryland may terminate any contract awarded and take any other appropriate action.
- 6. I affirm that this firm will not knowingly employ an individual to work at a school if the individual is a Registered Sexual Offender, pursuant to section 11-722 (C) of the Criminal Procedure Article of the Annotate Code of Maryland. A firm or person who violates this section is guilty of a misdemeanor and on conviction is subject to imprisonment not exceeding 5 years or a fine not exceeding \$5,000 or both.

The statements contained in this affidavit shall be incorporated into the awarded contract as material provisions and shall be effective throughout the life of the contract. The firm has a continuing obligation through the life of the contract to submit a revised affidavit should the firm discover information, or events occur, which render the contents of this affidavit erroneous or incomplete or which would result in the firm providing a different response. The firm's failure to submit a revised affidavit within three (3) working days of either its awareness of any error, change of circumstances, incompleteness, etc., or request by the owner shall constitute breach of contract. Upon submission of a revised affidavit, the owner has the right to take such actions as may be necessary, in the judgement of the owner, to maintain and enforce the provisions of the affidavit, including termination of the contract.

I DO SOLEMNLY DECLARE AND AFFIRM under the penalties of penalties that the contents of these affidavits (Statutory and Non-Collusion) are true and correct, that I am executing this Affidavit in compliance with Section 16-311 of the State Finance and Procurement Article, Annotated Code of Maryland, and the Non-Collusion Certification in compliance with requirements of the Board of Education of Howard County Maryland, and that I am executing and submitting this Form of Proposal on behalf of and with full authority by the bidder named below.

(Witness)

(Signed)

(Title)

SUBSCRIBED AND SWORN to before me on this _____ day of _____, 1999.

NOTARY PUBLIC

My Commission Expires:

(Legal Name of Company)

(Address)

(City)

(State)

(Zip)

(Telephone)

(Fax)

Contractor's # _____

We are/I am licensed to do business in the State of Maryland as a:

Corporation Partnership Individual Other



STANDARD CONTRACT

Attachment H AGREEMENT FOR PROFESSIONAL SERVICES

AGREEMENT # _____

THIS AGREEMENT is entered into this ____ day of _____ 2018, by and between the Board of Education of Howard County (hereinafter referred to as the "Board") and _____, (hereinafter referred to as the "Consultant").

RECITALS

WHEREAS, the Consultant submitted a proposal to RFP # issued by the Board and has been selected to perform ____ (scope) _____ services in accordance with the terms and conditions expressed in the RFP;

WHEREAS, the Board desires the Consultant to perform certain work and services, on the terms and conditions herein set forth and the Consultant is ready, willing, and able to perform such work and services; and

WHEREAS, this Agreement shall be administered by the Project Manager or such other persons designated by The Board of Education; and

NOW, THEREFORE, in consideration of the premises contained herein and the promises each to the other made, the parties hereby agree as follows:

ARTICLE I - CATEGORY OF WORK AND SERVICES

The work and services to be performed by the Consultant shall be in accordance with the following documents:

RFP # _____
Proposal Response per dated _____.

ARTICLE II - TERMS AND CONDITIONS

Consultant agrees to perform the work and services required under this Agreement in accordance with RFP # _____ whose general terms, conditions and specifications and General Provisions for Professional Services are incorporated herein by reference.

ARTICLE III - TERM OF AGREEMENT

The term of agreement shall begin on the date indicated above and continue for a period of one year commencing on _____ and terminating _____. The agreement may be extended an additional four (4) one year periods subject to funding.

ARTICLE IV - PAYMENTS AND SCHEDULE OF PAYMENTS

(1) The Consultant shall receive his full compensation for all work and services performed according to conditions outlined in the solicitation.

(2) Payment shall be made in three installments upon submission of an invoice.

ARTICLE V - INSURANCE

The Consultant agrees to and has complied with the insurance requirements set forth in the RFP.

IN WITNESS WHEREOF, the parties have executed this Agreement as of the day and year first above-written.

WITNESS:

BOARD OF EDUCATION OF HOWARD
COUNTY

By: _____(SEAL)
Cynthia L. Vaillancourt, Chairman
Board of Education of Howard County

APPROVED:

By: _____(SEAL)
Michael J. Martirano, Superintendent
Howard County Public School System

WITNESS:

By: _____
Signature

Typed Title

Company Name

Address

City, State Zip

Telephone Fax