

**HAMMOND HIGH SCHOOL
RENOVATION AND ADDITION**

ADDENDUM NO. 8

DATE: August 5, 2020

ARCHITECT: Smolen, Emr, Ilkovitch Architects, Inc.
9211 Corporate Blvd., Suite 340
Rockville, Maryland 20850
Phone: (301) 770-0177
Fax: (301) 330-3224

OWNER: Howard County Public School System

PROJECT: Hammond High School Renovation and Addition
Columbia, Maryland
Architect Project No. 18011

TO: All Prospective Bidders

The following changes are made a part of the Drawings and Specifications for the subject project, dated February 25, 2020. Receipt of this Addendum is to be acknowledged, in the space provided in the Bid Form. Failure to do so may subject the Bid to be considered as non-responsive.

Note that Addenda 1 through 7 were issued during the initial bid of this project. These documents were included within the bid documents for the 12A Rebid. Bidders do not have to acknowledge Addenda 1 through 7 on their bid form.

A. REQUESTS FOR INFORMATION

BID RFIs 1 through 123 were received and answered within Addenda 1 through 7. These Addenda were included within the 12A rebid documents.

124. This project requires the millworker to have 25% MBE. I stated that New Era is not an MBE Enterprise. In order to stay in compliant to this project, Can New Era purchase materials from MBE Vendors to meet the 25%?

RESPONSE: Prime contractors can be MBE or not MBE, but regardless they are still required to follow the MBE program.

Therefore, Attachment B outlines how much participation they can gain from the different types of MBE firms.

MBE as the prime can count 50% toward the goal

MBE as sub providing labor/work can count 100%

MBE as supplier (not doing any work) can count 60% toward the goal.

So for this question, yes the contractor can purchase the product from an MBE, but can only count 60% of the value toward the overall goal.

125. There is Wenger Music Casework shown on the drawings and scheduled on drawing A9.11. Music casework is not referenced in the specifications and does have differences in specification than that of section 123200. Shelves and grille doors are examples. Will a music casework section be issued for the project and included in the 12A Scope? Currently Music casework is not included in the 12A Scope as written.

RESPONSE: Music casework shall be included in the 12A Contract package. Provide the model cabinets listed within the contract documents. Provide manufacturer's standard shelving and grille doors.

**HAMMOND HIGH SCHOOL
RENOVATION AND ADDITION**

126. Science Casework Notes on drawing A9.11 state science casework is to be Stevens Advantage which suggests it is P Lam per section 123200. Specification Section 123553 specifies Wood Laboratory Casework. Please confirm all Science Casework shall be in accordance with section 123553.

RESPONSE: All science casework shall be in accordance with section 123553

127. Section 018113 Sustainable Design Requirements requires the project to meet LEED V4. Regional Materials for LEED V4 requires material be harvested and manufactured within 100 miles of the project site. We can make a solid effort to do so, as we have manufacturing in Manassas VA but cannot guarantee materials will be available as harvested within the 100 mile radius of the project site. If materials are not able to be harvested within 100 miles, will the requirement be enforced at 500 miles (the old standard)?

RESPONSE: USGBC will not permit enforcement of the old standard. Regional materials are required as a whole for the project. 12A contractor is to coordinate with all other prime contractors to ensure the project as a whole meets this threshold. 12A contractor is not required to use regional materials, but is encouraged to provide if possible to meet this overall project requirement.

128. We are able to provide Wenger Music Casework and/or Melhart Music Casework (an equal). I would not want this to be an item that gets us disqualified, so I am asking if you all could let me know if the owner has reservations regarding substitutions for Wenger. If you can give me a heads up, that would be much appreciated.

RESPONSE: Contractor is to base their bid on Wenger. Contractor may submit a substitution request with their bid per AIA A701 3.3 for consideration after the receipt of bids.

129. Can you please advise on Drawing #A9.05 at Room # E104 if there is any casework needed on the West Wall?

RESPONSE: Casework is needed on the west wall of E104. Include the following items within the bid for this room:

- One (1) C-31.36 cabinet
- Three (3) C-02.30 cabinets
- One (1) C-15.32 work surface/brackets
- One (1) C-12.36 sink cabinet

130. On the Bid Set Contract Package (01 02 00 - 55) 12A Re-Bid, Section K. Contract Package - 12A – Casework, the first sentence states:
"Contractor shall provide all labor, material, equipment, and supervision necessary for and reasonably incidental to the completion of Mechanical/Plumbing, in accordance with the complete set of Contract Documents." Please confirm the contract package is for casework only as defined in the specification sections and no mechanical or plumbing is included.

RESPONSE: First section shall be revised to the below:

"Contractor shall provide all labor, material, equipment, and supervision necessary for and reasonably incidental to the completion of Casework, in accordance with the complete set of Contract Documents. The scope of work of this Contract Package includes, but is not limited to, all work described in the following specification sections: "

131. On the Bid Set Contract Package (01 02 00 - 55) 12A Re-Bid, Section K. Contract Package - 12A– Casework, the specification sections include "12 35 53.19 Wood Laboratory Casework." Please confirm this should read "12 35 53 Wood Laboratory Casework" per the specifications.

**HAMMOND HIGH SCHOOL
RENOVATION AND ADDITION**

RESPONSE: The specification section number 12 35 53 Wood Laboratory Casework that is consistent with the table of contents was the intended reference.

132. On the Bid Set Contract Package (01 02 00 - 55) 12A Re-Bid, Section K. Contract Package - 12A – Casework, line #8 states:

“Contractor, two weeks prior to completion of the project, or as directed by the Construction Manager during a particular phase, shall scrupulously clean all casework tops, shelves, and doors, and clean interior spaces of all items installed under this contract.”

Please clarify in more detail the expectations of “scrupulously clean.” Otherwise, please confirm that broom swept (removal of dirt/dust) and wiped down will be acceptable and that final clean will be performed by others.

RESPONSE: Rough cleaning shall be to the satisfaction of the Construction Manager and Architect upon completion of installation. Any deficiencies will be noted in writing.

The 1A Prime Contractor is responsible for final cleaning.

132. On the architectural plans; “Casework Legends” sheets A9.10, A9.11, and A9.12, there are no details showing locks on the casework. Please confirm locks are required on all casework doors and drawers per specification section 12 32 00 (2.4-G-2).

RESPONSE: Confirmed. Provide locks as listed within the project specifications.

133. Specification section 12 32 00 (1.3-E) states:

“Submit complete selection of available Wilsonart or Formica plastic laminate color samples for selection by the Architect.”

Both manufacturers have a wide range of color offerings with varying price ranges. Please confirm “complete selection” of colors refers to only their solid, base-line color selections for High-Pressure Laminate with a matte finish (per 2.2-A-2).

RESPONSE: Include all ‘Standard’ laminates. ‘Premium’ laminates may be excluded.

134. At the Science laboratory casework assemblies (example S-08/A9.11) there are identifiers noted at the bottom of each assembly section. Bolded text appears to identify if exhaust, gas, water, and or electric are to be utilized. S-08 has gas, water and electric bolded. The graphic detail shows a standard vacuum breaker mixing valve faucet and no other type of fixtures. Please confirm if the faucet is to be a combination faucet. See detail below

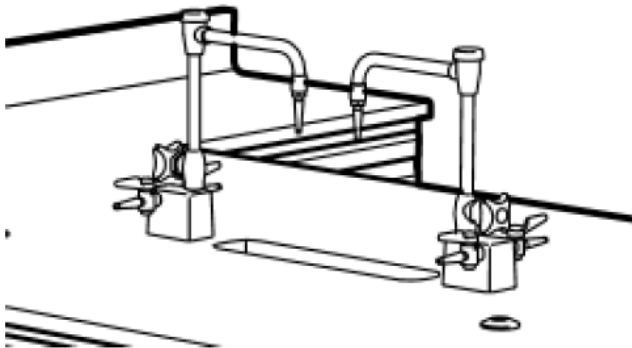

RESPONSE: Either a combination faucet or separate gas turrets will be acceptable.

**HAMMOND HIGH SCHOOL
RENOVATION AND ADDITION**

135. Architectural plans sheet A9.11 Casework Legend denotes a “Goggle Cabinet” (S-23.**). There are no details describing this cabinet. Please confirm the goggle cabinet is a standard wood, wall mounted, three shelf cabinet with no sanitizing capabilities.

RESPONSE: Goggle cabinet S-23 is to have sanitizing capabilities through electrically powered UV light. See bolded ELEC in science casework schedule and review basis of design Stevens Advantage cabinet model 52192 as listed in the schedule.

136. Per specification section 12 35 53 (2.7-D) and architectural sheet A9.11 Scientific Casework note #3 (The second #3 in the notes) all countertops are to be epoxy. Note #7 on the same sheet A9.11 states: “ALL EXPOSED EDGES, EXCEPT TOPS OVER 6'-0", ARE TO BE FINISHED WITH PLASTIC LAMINATE TO MATCH RELEVANT CASEWORK.” Please confirm all countertops for the scientific casework are to be epoxy and do not require plastic laminate edges.

RESPONSE: All countertops for the scientific casework are to be epoxy and do not require plastic laminate edges.

137. Per specification section 12 35 53 (2.7-D-4-a) epoxy countertops are to be 1” thick. Architectural sheet A9.11 Scientific Casework note #3 (The second note# 3) states epoxy tops are to be 1 ¼” thick. Please confirm epoxy countertops are to be the industry standard 1” thick.

RESPONSE: Confirmed. All epoxy countertops are to be 1” thick.

138. Per specification section 12 35 53 (3.4-A) epoxy sinks are to be installed as undermount sinks. ADA sinks (S-02) require a drop in sink mounting to conform with sloped cabinet design. See details below. Please confirm drop-in sinks are acceptable at ADA sink locations.

RESPONSE: Confirmed. Drop-in sinks are acceptable at ADA sink locations.

139. Architectural plans sheet A9.04, Room D129 has detail S-15.36 noted. Casework legend does not have this designation detailed. Please confirm what S-15.36 is and if it is in our scope of work.

RESPONSE: This item should be labeled S-12.36.

140. Architectural plans sheet A9.04, Room D129 has detail DR-3 noted. There are two of them and they appear to be pegboard/drying racks. Casework legend does not have this designation detailed. Pegboards are in specifications section 12 35 53 (2.8.B.) but no dimensions are noted. Please confirm the DR-3 designation is pegboard/drying racks. Please confirm epoxy pegboard with polypropylene pegs and stainless-steel drip trough with standard size 32” L by 30” H is acceptable.

RESPONSE: Confirmed, DR-3 are to be pegboard drying racks (epoxy pegboard with polypropylene pegs and stainless-steel drip trough). 32” x 30” is acceptable.

141. Addendum 2, RFI#6 asks for clarification of the material for the scientific casework because the plans denote plastic laminate and the specifications denote wood casework. The response states the “Stevens Advantage number to describe basis of design casework size/layout. Construction to meet requirements listed in Specification section 123553 Wood Laboratory Casework.” Please confirm that the Science Casework (per A9.11) must be provided by one of the acceptable manufacturers listed in the Wood Laboratory Casework specification 12 35 53 (2.1-A).

HAMMOND HIGH SCHOOL RENOVATION AND ADDITION

Furthermore, please confirm that the Science Casework should be wood veneer per specification 12 35 53 and not laminate casework as suggested by the A9.11 Casework Legend and Basis of Design listed in the Notes.

RESPONSE: Confirmed. All items must be provided by an acceptable manufacturer listed in section 12 35 53. All items should be wood veneer per section 12 35 53.

141. During the Pre-bid meeting there were discussions about the #1-8 Alternates and that no pricing was needed for the 12A- Rebid pricing. Alternate #2 and #8 were priced in the original bidding and appear to have casework in them. Please confirm that no pricing is needed for any of the 01 23 00 – Alternates in this 12A – Casework Re-Bid.

RESPONSE: This is not correct. Contractor is to include pricing for all the alternates listed on the bid form.

B. CHANGES TO SPECIFICATIONS

- Section 123216 – Manufactured Plastic-Laminate Faced Casework
 - **ADD** subparagraphs 2.1.A.2.i & j as follows:
 - i. USA Millwork (and subsidiaries)
 - j. Mastercraft Woodworking Company, Inc.

C. CHANGES TO DRAWINGS

- A9.04 PARTIAL CASEWORK PLAN – FIRST FLOOR – AREA D
 - **REVISE** casework tag in room D129 from S-15.36 to S-12.36
- A9.05 PARTIAL CASEWORK PLAN – FIRST FLOOR – AREA E & F
 - **ADD** the following tags to the casework on the plan west wall of room E104
 - One (1) C-31.36 cabinet
 - Three (3) C-02.30 cabinets
 - One (1) C-15.32 work surface/brackets
 - One (1) C-12.36 sink cabinet

D. ATTACHMENTS

- Pre-Bid Meeting Minutes

END OF ADDENDUM NO. 8

Hammond HS Pre-Bid Meeting Minutes

Meeting Type: Pre-Bid Meeting
Meeting Number: Meeting 001
Date: Tuesday, July 28, 2020 @ 2:00 PM
Location: Virtual
Author: Tom Kraft
Next Meeting: N/A

Attendees:

Danny Clark (Steel Products)
Matthew Gage (New Era Custom Design)
Robert Gill (HCPSS)
Tom Kraft (JVS)
Dave Fischer (SEI)
Mike Lipcheck (USA Millwork)
Leslie Leam (Crescent Construction)
Dominic Long (ISEC)
Dan Lubeley (HCPSS)
Chad Porter (HCPSS)
Chris Roland (Roland Plumbing)
John Serd (Crescent Construction)
Gene Shanholtz (JVS)
Patricia Siano (ATC)
Marken Smith (Post Construction)

New Business

001 - General Bid items

- Pre-Bid Meeting was recorded.
 - J. Vinton Schafer (JVS) is under contract with the Howard County Public School System (HCPSS) for Construction Management Agency services for the Hammond High School Renovation and Addition Project.
 - All Prime Contracts will be held by HCPSS.
 - All Sub Contractors and/or vendors shall bid to potential Prime Contract bidders.
 - Bid documents and addenda can be downloaded from JVS's website. Contact Tom Kraft for access. All Questions shall be in writing to Tom Kraft at JVS. tomk@jvschafer.com or 410-335-3000.
 - This Bid is for the 12A – Casework PACKAGE ONLY. All other packages have been released.
-

002 - Project Overview

- The project will be phased and occupied.
- The overall project scope is inclusive of a full renovation and addition of the existing school.
 - o 10 phases
 - o Approximately 3 year schedule
 - o Site package inclusive of football stadium
 - o Approx. 100,000 sqft of addition
 - o Total project is approx. 240,000 sqft

- The work for temporary areas to be installed in summer of 2020 has been removed from the scope of this contract package.
 - The project has prevailing wage/certified payroll requirements
 - The project has thirteen Prime Contractor packages (1A, 2A, 3A, 4A, 5A, 7A, 8A, 9A, 9E, 11A, 12A, 15A and 16A). Close coordination between multiple prime contractors is a MUST.
 - This Bid is for the 12A – Casework PACKAGE ONLY. All other packages have been released.
 - Bidders must bid on the package as a whole. No qualifications or exclusions will be accepted. Bidders are reminded that there are multiple types of casework included in the 12A Contract Package.
 - This is a LEED Project.
 - Contractors shall plan to provide manpower for the project accordingly to complete the work within the schedule constraints. In the event additional hours/shifts are needed this will be coordinated with the Owner and Construction Manager at no cost to the Owner. Summer schedules shall have 6-day work weeks from ALL Prime Contractors. Work performed in limited access areas (landlocked) shall be worked on after school hours.
 - HCPSS advised that all HCPSS and State rules and regulations would apply to this project for working on an occupied school site.
 - Bidders should review the schedule included in the bid documents and plan resources accordingly to accommodate the schedule.
 - Contact J. Vinton Schafer & Sons to schedule a site visit
-

003 Procurement Items

- HCPSS reminded all bidders that they are bidding on the complete set of project documents. Bidders are reminded to download the complete set of project documents from JVS' website including any addenda posted.
- Bidders were reminded that all RFIs, ASIs, RFPs, and Addenda 1-7 from the original bid shall be the basis for the current bid proposal. These items do not need to be noted on the bid proposal form. ONLY ADDENDA POSTED AFTER JULY 21, 2020 NEED TO BE NOTED ON THE BID PROPOSAL FORM.
- Alternates were reviewed.
- Unit Prices were reviewed.
- HCPSS reminded that any discussions would not be binding unless it is in writing in addenda. Do not contact HCPSS or any members of the design team to discuss the project.
- HCPSS reviewed all purchasing/bidding requirements.
- HCPSS reviewed all MBE goals. All bidders are encouraged to thoroughly review the MBE documentation requirements. Original MBE attachment "B" is to be submitted with bid proposal. The revised attachment "B" will be submitted by apparent low bidder after bid pending acceptance of alternates.
- HCPSS advised that all bid proposals must be on HCPSS' proposal form and submitted ELECTRONICALLY AS PER BIDDING INSTRUCTIONS.
- Bids will be publicly in a virtual setting.
- HCPSS' Standard Form of Agreement, insurance requirements, P&P bonds, Bid Bond, General Conditions and MBE requirements/forms are included in the bid documents and were reviewed. Bidders were reminded to use the HCPSS forms and to utilize the firms full legal name on all documents. Whomever signs the proposal form and bonds must have the authority to do so from their respective firm.
- Substitutions must be submitted per bid document requirements. Backup paperwork must be provided with request.
- Proposal checklist was reviewed
- HCPSS reviewed the criminal background check document.
- Prime Contractors shall be responsible for performing criminal background checks on all employees working on site. The costs of the background checks shall be borne by the Prime Contractor. Background checks from other jurisdictions will not be accepted.

The above minutes represent the author's interpretation of the Hammond High School Renovation and Addition 12A Contract Package Pre-Bid Meeting. All meeting minute items are considered correct and accurate unless the author is notified in writing within three (3) days.

Signature: *Tom Kraft*

Date: 8/4/2020
